



SLG系列不锈钢立式多级泵(50HZ)

SLG SERIES STAINLESS STEEL VERTICAL MULTI-STAGE PUMP (50HZ)



上海连成（集团）有限公司
SHANGHAI LIANCHENG (GROUP)CO.,LTD.

地址：上海市江桥镇曹安公路3616-3618号
邮编：201812
总机：(021) 59138888
传真：(021) 59136782
800免费咨询电话：800-820-5009
400免费咨询电话：400-188-3339

Address:3616-3618 Can'an Road, Jiangqiao Shanghai
P.C.: 201812
Switchboard: (021) 59138888
Fax: (021) 59136782
800 Free consultation Tel: 800-820-5009
400 Free consultation Tel: 400-188-3339



连成集团微信订阅号

目录

CONTENTS

性能范围、产品范围 Performance range, Product range	1
产品概述、运行条件、型号说明 Outlina of product, Running condition, Model meaning	2
主要用途、电机 Main purpose, Motor	3
电动机及泵产生的噪音 Noise produced with both motor and pump	3
结构简图 Structure drawing	4
最大工作压力 Maximum working pressure	7
最大环境温度 Maximum environment temperature	7
最小进口压力 Minimum inlet pressure	8
性能曲线 Performance curve	9
性能表及安装尺寸图表 Performance table and installation dimension	11

性能范围 Performnace range

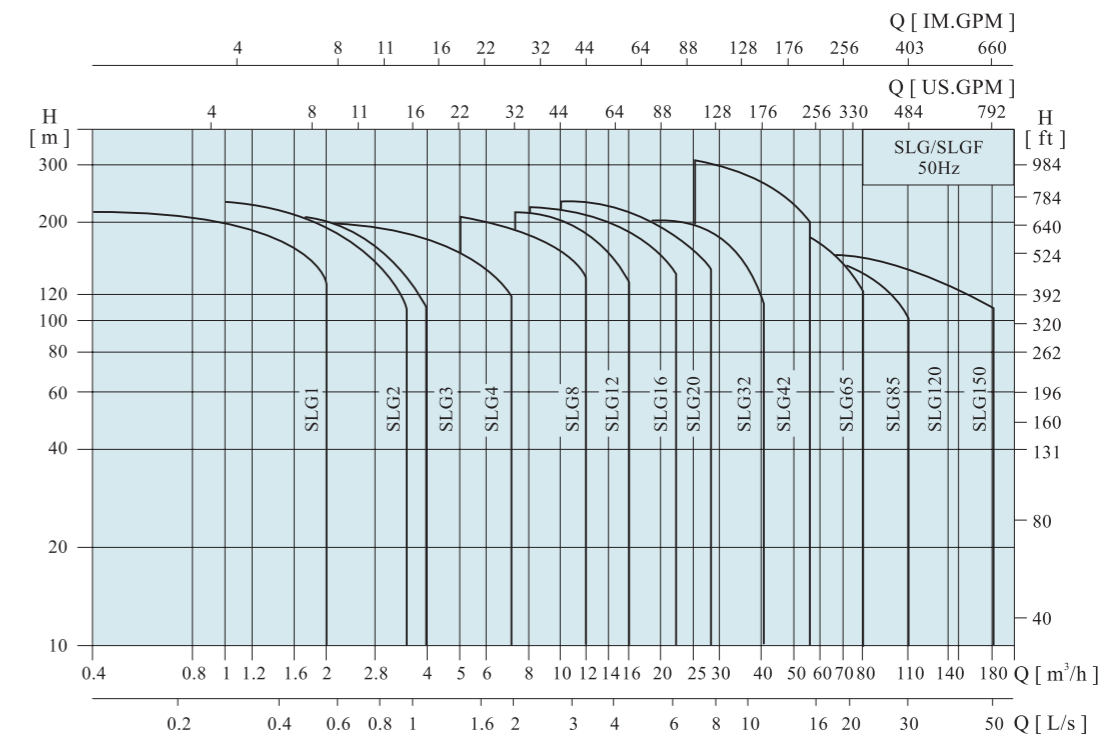

产品范围 Product range

说明 Description	SLG1	SLG2	SLG3	SLG4	SLG8	SLG12	SLG16	SLG20	SLG32	SLG42	SLG65	SLG85	SLG120	SLG150
额定流量 (m³/h) Rated flow	1	2	3	4	8	12	16	20	32	42	65	85	120	150
额定流量 (L/s) Rated flow	0.28	0.56	0.83	1.1	2.2	3.3	4.4	5.6	8.9	11.7	18	24	33	41.6
流量范围 (m³/h) Range of flow	0.4-2	1-3.5	1.2-4	1.5-7	5-12	7-16	8-22	10-28	16-40	25-55	30-80	50-110	60-150	80-180
流量范围 (L/s) Range of flow	0.11-0.56	0.28-0.97	0.33-1.1	0.42-1.9	1.4-3.3	1.9-4.4	2.2-6.1	2.8-7.8	4.4-11.1	6.9-15.3	8.3-22.2	13.8-30.5	16.7-41.7	22-50
最大压力 (bar) Maximum pressure	21	23	22	21	21	22	22	23	26	30	22	17	16	16
电机功率 (kW) Power of motor	0.37-2.2	0.37-3	0.37-3	0.37-4	0.75-7.5	1.5-11	2.2-15	1.1-18.5	1.5-30	3.0-45	4.0-45	5.5-45	11-75	11-75
温度范围 (°C) Range of temperature	-15~+120													
最高效率 (%) Maximum efficacy	44	46	54	59	64	63	66	69	76	78	80	81	74	73
类型 Type														
SLG	●	●	●	●	●	●	●	●	●	●	●	●	●	●
SLGF	●	●	●	●	●	●	●	●	●	●	●	●	●	●
SLG管路联接 SLG pipeline link														
DIN法兰 DIN flange	DN25	DN25	DN25	DN32	DN40	DN50	DN50	DN50	DN65	DN80	DN100	DN100	DN125	DN125
椭圆法兰 Elliptical flange	G1	G1	G1	G1 1/4	G1 1/2									
SLGF管路联接 SLGF pipeline link														
DIN法兰 DIN flange	DN25	DN25	DN25	DN32	DN40	DN50	DN50	DN50	DN65	DN80	DN100	DN100	DN125	DN125
卡套接头 Ferrule joint	●	●	●	●	●	●	●	●						
管螺纹 Pipe thread	●	●	●	●	●	●	●	●						

产品概述 Outline of product

SLG/SLGF为安装标准电机的非自吸立式多级离心泵，电机轴通过电机座用联轴器直接与泵轴联接，拉杆螺栓将耐压筒、过流部件固定在电机座和进出水段之间，泵进出水口在泵底同一直线上；本泵可根据需要配置智能保护器，对泵干转、缺相、过载等进行有效保护。

SLG/SLGF are non-self-suction vertical multi-stage centrifugal pumps mounted with a standard motor, the motor shaft is linked, via the motor seat, directly with the pump shaft with a clutch, both pressure-proof barrel and flow-passing components are fixed in between the motor seat and the water in-out section with pull-bar bolts and both water inlet and outlet of the pump are positioned on one line of the pump bottom; and the pumps can be fitted with an intelligent protector, in case of necessity, to effectively protect them against dry movement, lack-of-phase, overload etc.

运行条件 Running condition

稀薄、干净、非易燃易爆并不含固体颗粒或纤维的液体。

液体温度：常温型-15℃~+70℃

热水型+70℃~+120℃

环境温度：最高+40℃

海拔：≤1000m

注：海拔大于1000米，选型时须特别提出。

Thin, clean, non-combustible non-explosive liquids containing no solid grains or fibers.

Liquid temperature: constant-temperature type -15~+70℃

hot-water type +70~120℃

Ambient temperature: max. +40℃

Elevation: max. 1000m

Note: please note it at the model selection in case the elevation is over 1000m.

型号说明 Model meaning

SLG, SLGF1,2,3,4,8,12,16和20

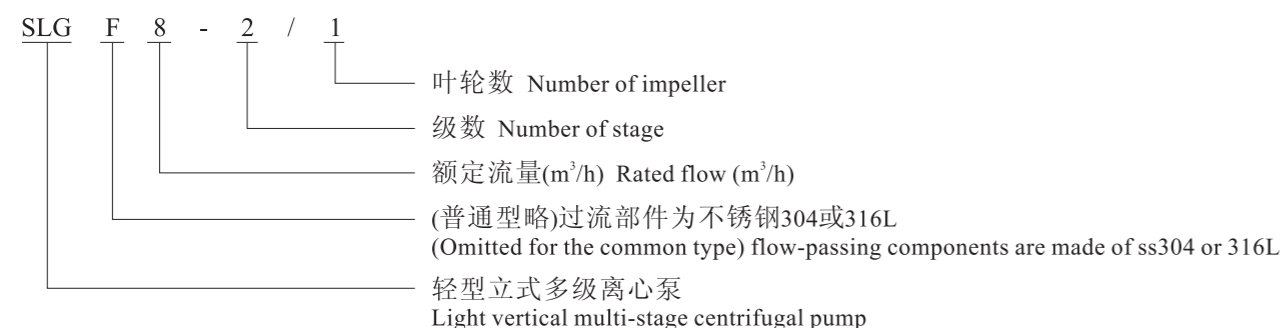

SLG, SLGF32,42,65,85,120和150

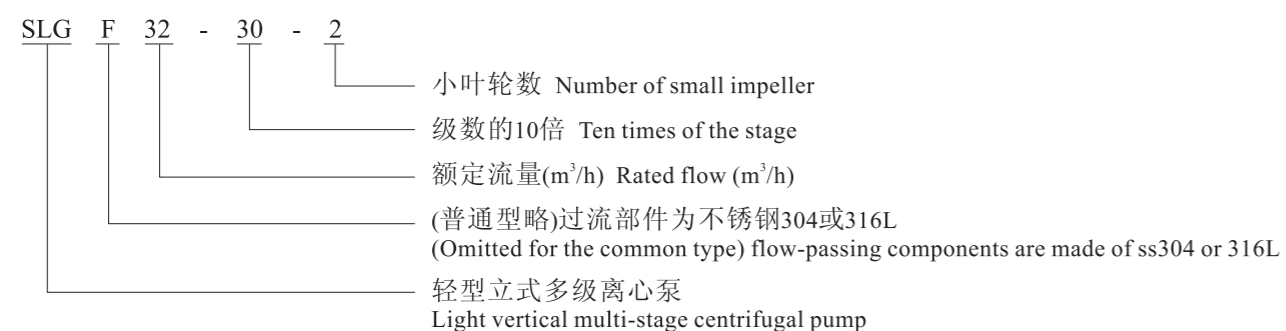

主要用途 Main purpose

SLG/SLGF是一种多功能产品，可以输送从自来水到工业液体的各种不同介质，适应于不同温度、流量和压力范围，SLG适用于无腐蚀性液体，SLGF适用于轻度腐蚀性液体。

供水：水厂过滤与输送，水厂分区送水、主管增压、高层建筑增压。

工业增压：流程水系统、清洗系统、高压冲洗系统、消防系统。

工业液体输送：冷却和空调系统、锅炉给水和冷凝系统、机床配套、酸和碱。

水处理：超滤系统、反渗透系统、蒸馏系统、分离器、游泳池。

灌溉：农田灌溉、喷灌、滴灌。

SLG/SLGF are the products of multiple functions, applicable for transporting various different media from tap water to industrial liquids and suitable for different ranges of temperature, flow and pressure. SLG is applicable for non-corrosive liquids while SLGF for lightly corrosive ones.

Water supply: filter and transportation and quartering water feed for water works, boost for main pipes and high buildings.

Industrial boost: flowing water system, cleaning system, high pressure rinsing system, fire fighting system.

Industrial liquid transportation: cooling & air-conditioning system, boiler water supply & condensing system, completion of machine tools, acid and alkali.

Water treatment: extra-filter system, reverse osmosis system, distilling system, separator, swimming pool.

Irrigation: farmland irrigation, sprinkler irrigation, trickle irrigation.

电机 Motor

电机为全封闭，风冷式二极标准电机。

防护等级：IP55

绝缘等级：F

标准电压：50Hz：1×220-230/240V

3×200-220/346-380V

3×220-240/380-415V

3×380-415V

The motor is a full closed, air-cooled two-pole standard one.

Protection rating: IP55

Insulation grade: F

Standard voltage: 50Hz: 1×220-230/240V

3×200-220/346-380V

3×220-240/380-415V

3×380-415V

电动机及泵产生的噪音 Noise produced with both motor and pump

电机 Motor(kW)	50Hz dB(A)	电机 Motor(kW)	50Hz dB(A)	电机 Motor(kW)	50Hz dB(A)
0.37	64	3	76	18.5	86
0.55	64	4	77	22	89
0.75	67	5.5	80	30	92
1.1	67	7.5	80	37	92
1.5	72	11	86	45	92
2.2	72	15	86		

注：公差为表中平均值±2。

Note: The tolerance to be ±2% of the average value in the table.

结构简图 Structure drawing

SLG, SLGF1,2,3,4 结构图 Structure drawing

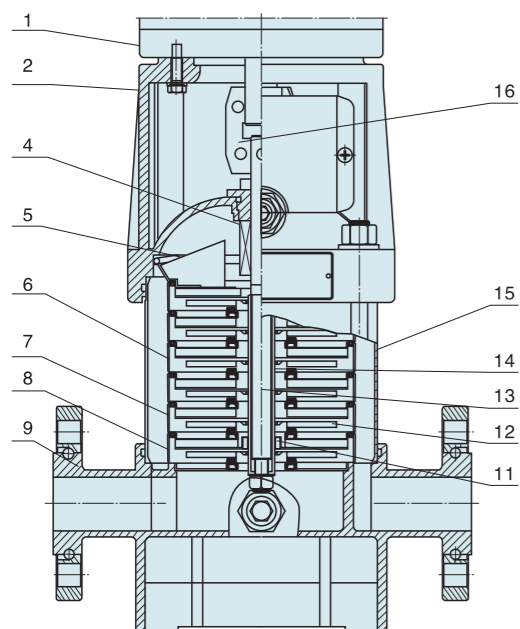

SLG

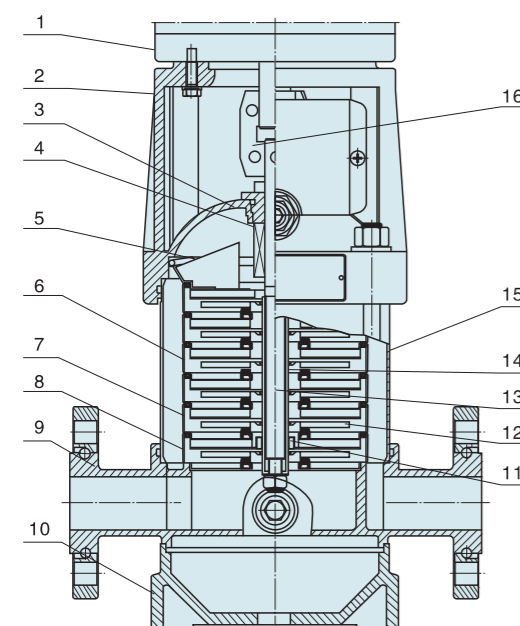

SLGF

序号 No	名称 Name	材料 Material
1	电机 Motor	
2	电机座 Motor base	HT150
4	机械密封 Mechanical seal	
5	出水导叶 Water-out guide vane	0Cr18Ni9
6	导叶 Guide vane	0Cr18Ni9
7	支撑导叶 Supporting guide vane	0Cr18Ni9
8	导流器 Flow deflector	0Cr18Ni9
11	轴承 Bearing	碳化钨 Tungsten carbide
12	叶轮 Impeller	0Cr18Ni9
13	轴 Shaft	0Cr18Ni9、 00Cr17Ni14Mo2
14	叶轮挡套 Baffle sleeve of impeller	0Cr18Ni9
15	外套筒 Outer sleeve	0Cr18Ni9
16	联轴器 Clutch	碳钢 Carbon steel
SLGF		
3	泵盖 Pump cover	0Cr18Ni9
9	进出水段 Water in-out section	0Cr18Ni9
10	底座 Foundation	HT150
SLG		
9	进出水段 Water in-out section	HT150

结构简图 Structure drawing

SLG, SLGF8,12,16,20 结构图 Structure drawing

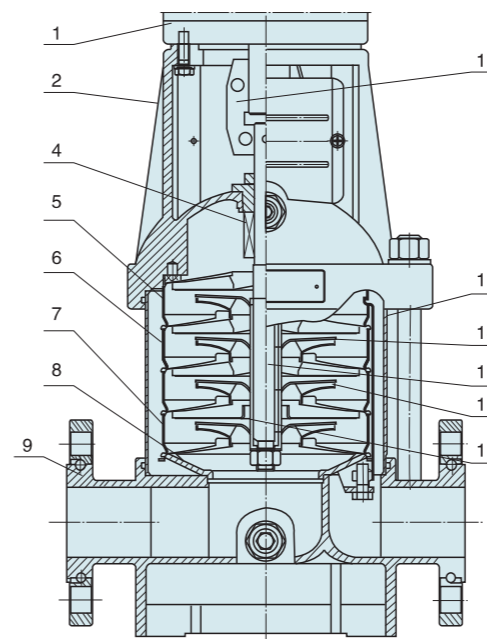

SLG

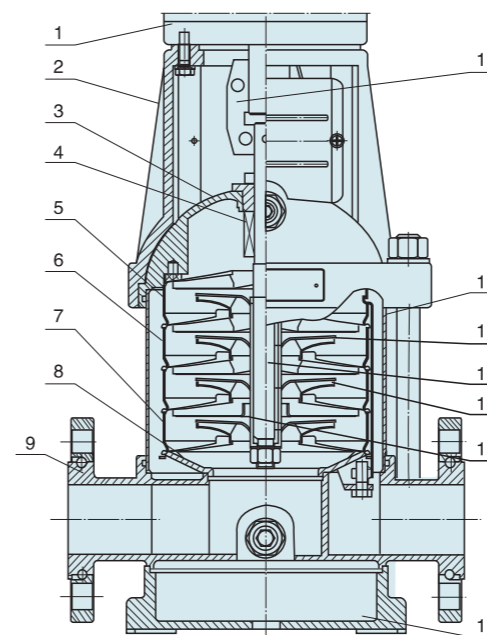

SLGF

序号 No	名称 Name	材料 Material
1	电机 Motor	
2	电机座 Motor base	HT150
4	机械密封 Mechanical seal	
5	出水导叶 Water-out guide vane	0Cr18Ni9
6	导叶 Guide vane	0Cr18Ni9
7	支撑导叶 Supporting guide vane	0Cr18Ni9
8	导流器 Flow deflector	0Cr18Ni9
11	轴承 Bearing	碳化钨 Tungsten carbide
12	叶轮 Impeller	0Cr18Ni9
13	轴 Shaft	0Cr18Ni9、 00Cr17Ni14Mo2
14	叶轮挡套 Baffle sleeve of impeller	0Cr18Ni9
15	外套筒 Outer sleeve	0Cr18Ni9
16	联轴器 Clutch	碳钢 Carbon steel
SLGF		
3	泵盖 Pump cover	0Cr18Ni9
9	进出水段 Water in-out section	0Cr18Ni9
10	底座 Foundation	HT150
SLG		
9	进出水段 Water in-out section	HT150

结构简图 Structure drawing

SLG, SLGF32,42,65,85 结构图 Structure drawing

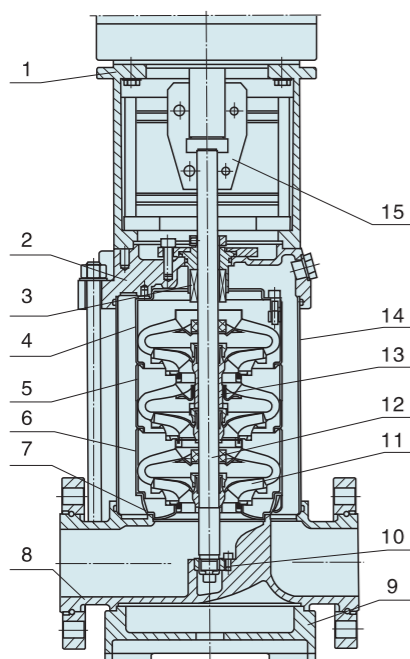

序号 No	名称 Name	材料Material	
		SLG, SLGF 32,42,65,85	SLG, SLGF 120,150
1	电机座 Motor base	HT150	HT150
3	机械密封 Mechanical seal		
4	出水体 Water-out body	0Cr18Ni9	0Cr18Ni9
5	支撑导叶 Supporting guide vane	0Cr18Ni9	0Cr18Ni9
6	导叶 Guide vane	0Cr18Ni9	0Cr18Ni9
7	导流器 Flow deflector	0Cr18Ni9	0Cr18Ni9
9	底座 Foundation	HT150	QT500-7
10	下轴承 Lower bearing	碳化钨 Tungsten carbide	
11	叶轮 Impeller	0Cr18Ni9	0Cr18Ni9
12	轴 Shaft	00Cr17Ni14Mo2 0Cr18Ni9 1Cr17Ni2	0Cr18Ni9
13	轴套 Muff	碳化钨 Tungsten carbide	碳化钨 Tungsten carbide
14	外套筒 Outer sleeve	0Cr18Ni9	0Cr18Ni9
15	联轴器 Clutch	碳钢 Carbon steel	碳钢 Carbon steel
	橡胶零件 Rubber parts	NBR	NBR
SLG			
2	泵盖 Pump cover	HT150	QT500-7
8	进出水段 Water in-out section	HT150	QT500-7
SLGF			
2	泵盖 Pump cover	0Cr18Ni9	0Cr18Ni9
8	进出水段 Water in-out section	0Cr18Ni9	0Cr18Ni9

SLG, SLGF120,150 结构图 Structure drawing

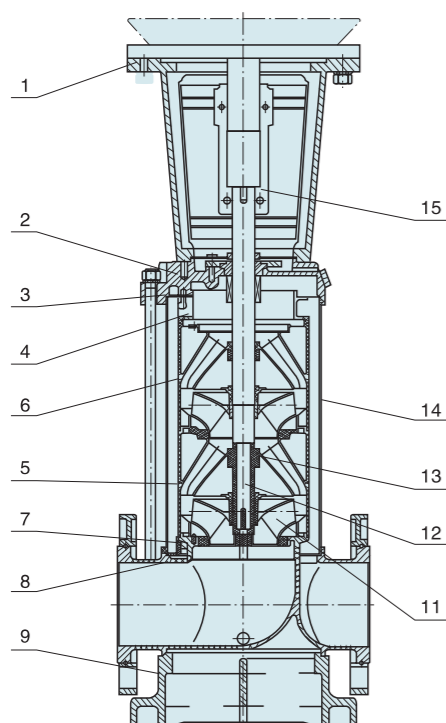

最大工作压力 Maximum working pressure

型号 Type	曲线号 No.curve
SLG1,2,3,4法兰 Flange	2
SLG1,2,3,4椭圆法兰	1
SLGF1,2,3,4	2
SLG8,12,16,20法兰	3
SLG8椭圆法兰	1
SLGF8, 12, 16, 20	3
SLG, SLGF32	
32-10-1~32-70	1
32-80-2~32-120	4
32-130~32-140	5
SLG, SLGF42	
42-10-1~42-60	4
42-70-2~42-90	4
42-100-2~42-130-2	5
SLG, SLGF65	
65-10-1~65-50	1
65-60-2~65-80-1	4
SLG, SLGF85	
85-10-1~85-50-2	1
85-50~85-60	4
SLG, SLGF120,150	6

下图表示压力和温度的极限，压力和温度须在所示范围内。

The chart below shows the limits of both pressure and temperature, and both have to be within the shown range.

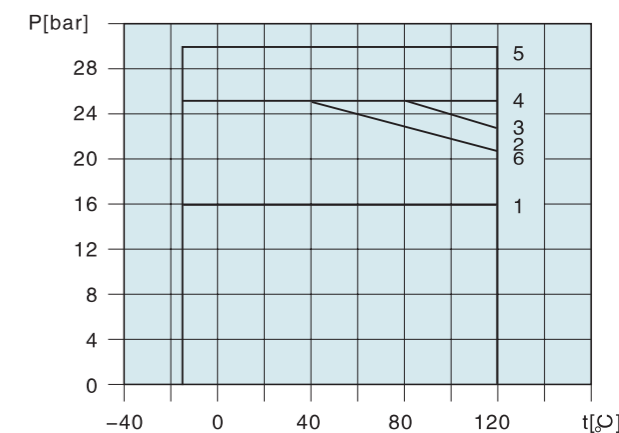

最大环境温度 Maximum environment temperature

当泵在环境温度大于40℃或海拔大于1000m下运行时，由于空气密度低冷却效果差，电机输出功率P₂会有一定降低。泵在上述情况下运行电机功率需配大。

When the pump works at an ambient temperature over 40℃ or at an elevation over 1000m, the output power of the motor may be certainly lowered because of the low air density and a poor cooling effect and a motor of a heavier power needs to be provided then.

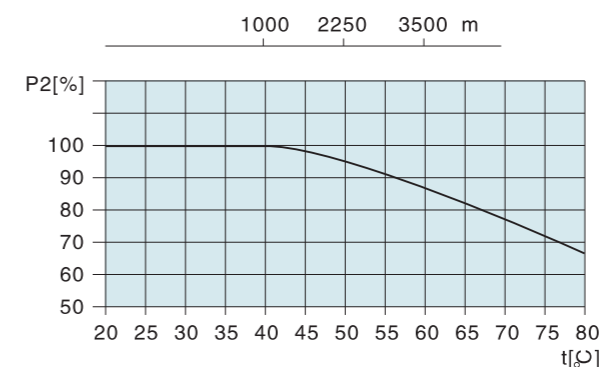

最小进口压力 Minimum inlet pressure

如果泵中的压力低于输送液体的汽化压力，可能发生气蚀，为避免气蚀，确保泵进口侧有一最小压力，最大吸程H(m)可按下式计算：

$$H = P_b \times 10.2 - (NPSH)r - H_f - H_v - H_s$$

Pb=大气压力(bar)

(大气压力可设定为1bar)

在闭式系统中，Pb为系统压力(bar)

NPSH=净正吸头(m)

(可从NPSH曲线上泵可能的最大流量处读取)

Hf=入口的管路损失(m)

Hv=汽化压力(m)

Hs=安全余量=最小0.5m水头

如计算所得H为正值，泵可在最大吸程H情况下运行。

如计算所得H为负值，必须有一最小进口压力H的水头。

Gas etching may occur in case the pressure inside of the pump is lower than the steam pressure of the liquid being transported and, to avoid it, it shall be done to ensure a minimum pressure on the inlet side of the pump. The maximum suction head H(m) can be calculated by the formula below:

$$H = P_b \times 10.2 - (NPSH)r - H_f - H_v - H_s$$

Pb=atmospheric pressure (bar)

(the atmospheric pressure can be set as 1bar)

In a closed system, Pb is the system pressure (bar)

NPSH=net positive suction head (m)

(can be read at the pump's possible maximum flow on the NPSH curve)

Hf=the pipeline loss at the entrance(m)

Hv=the steam pressure (m)

Hs=safety margin =minimum 0.5 water head

The pump can run under the maximum suction head H if the calculated value H is a positive one and, in case of a negative one, there shall be a water head of a minimum inlet pressure H.

检查确保泵不会/没有处于气蚀状态

Check to make sure the pump can not be/is not in the gas etching state

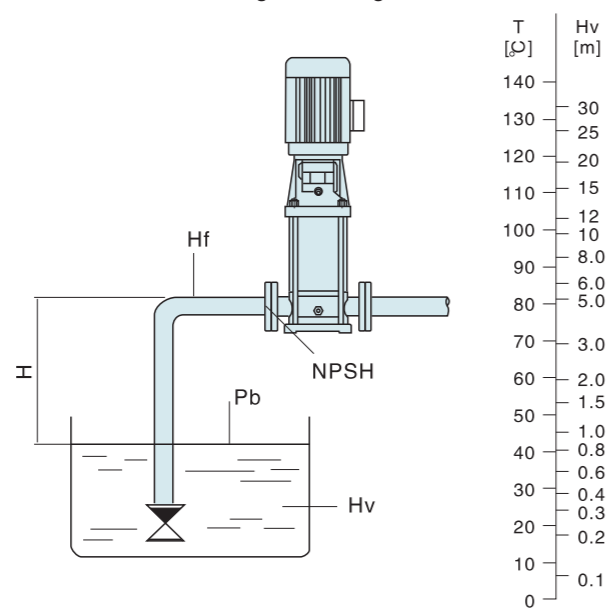

承压件试验压力 Test pressure of pressure parts

泵进出水段做静水压试验，保持压力为允许进口压力与最高级数泵的工作压力之和的1.5倍，保压时间不少于5分钟。保证无泄漏、渗漏、冒汗等缺陷现象，通常取允许进口压力为0.4MPa。

Section do hydrostatic pressure test pump in and out of the water, or keeping pressure to allow imports with the highest series pump working pressure of 1.5 times, the sum of the holding time of not less than 5 minutes. Ensure that no defects such as leakage, leak, sweating, usually take to allow inlet pressure is 0.4 MPa.

性能曲线 Performance curve

下列说明适用于后面所示的曲线：

- 1、所有曲线都基于电机在恒速2900rpm或2950rpm的测量值。
- 2、曲线容差符合ISO9906，附录A。
- 3、测试采用20℃不含空气的水，运动粘度为1mm²/s。
- 4、泵的使用参照加粗曲线的性能范围，以防发生流量过小导致泵体过热和流量过大使电机过载等现象。

The description below is applicable for the curves shown on the back:

1. All the curves are based on the values measured at the constant speed of 2900rpm or 2950rpm of the motor.
2. The allowed curve differences comply with ISO9906, Appendix A.
3. The water at 20°C containing no air is used for the measurement, the moving viscosity of it is 1mm²/s.
4. The pump shall be used within the performance range shown by the thickened curves so as to prevent against over-heat due to an undersized flow and prevent the motor against overload due to an oversized flow.

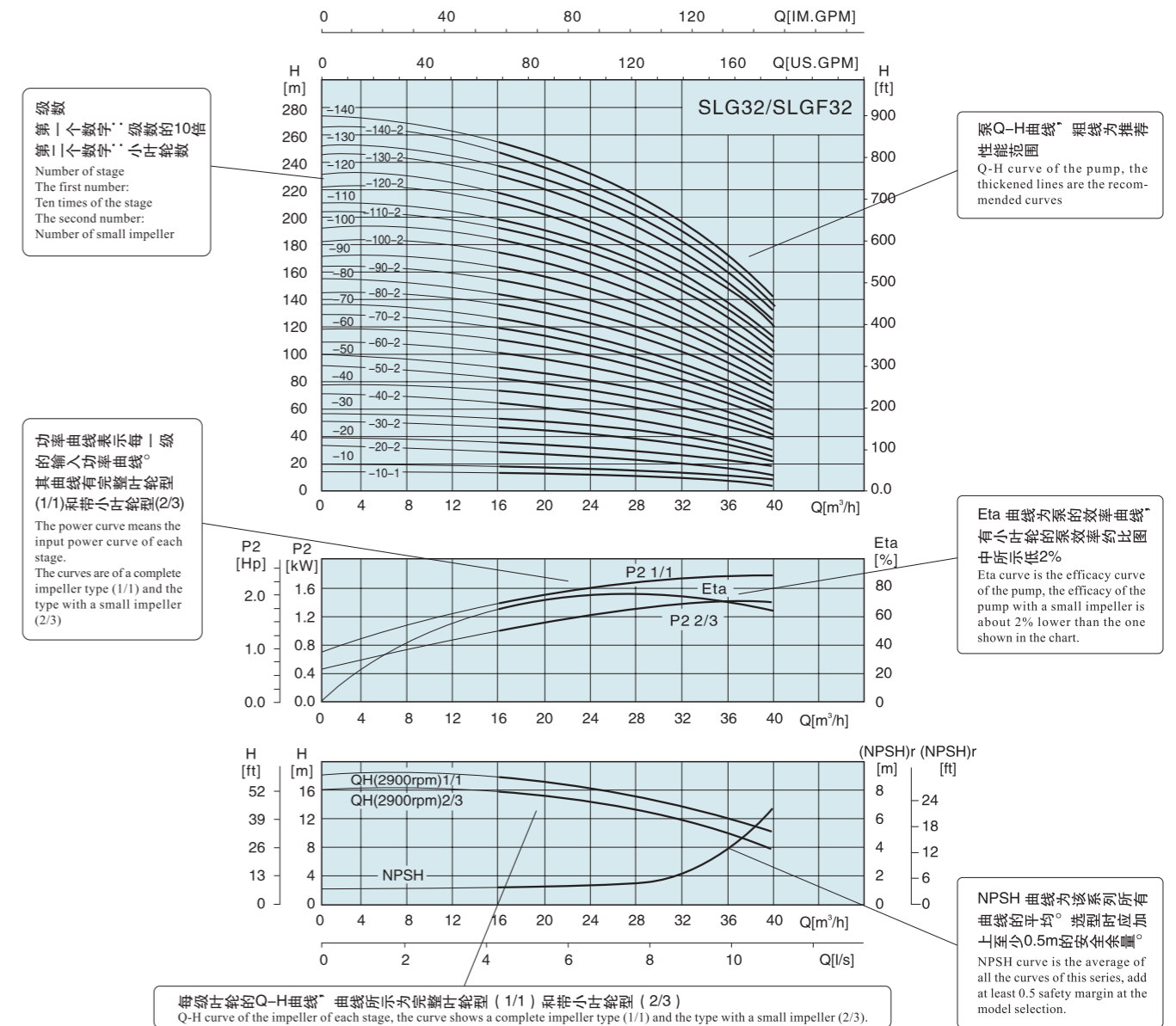

性能曲线 Performance curve

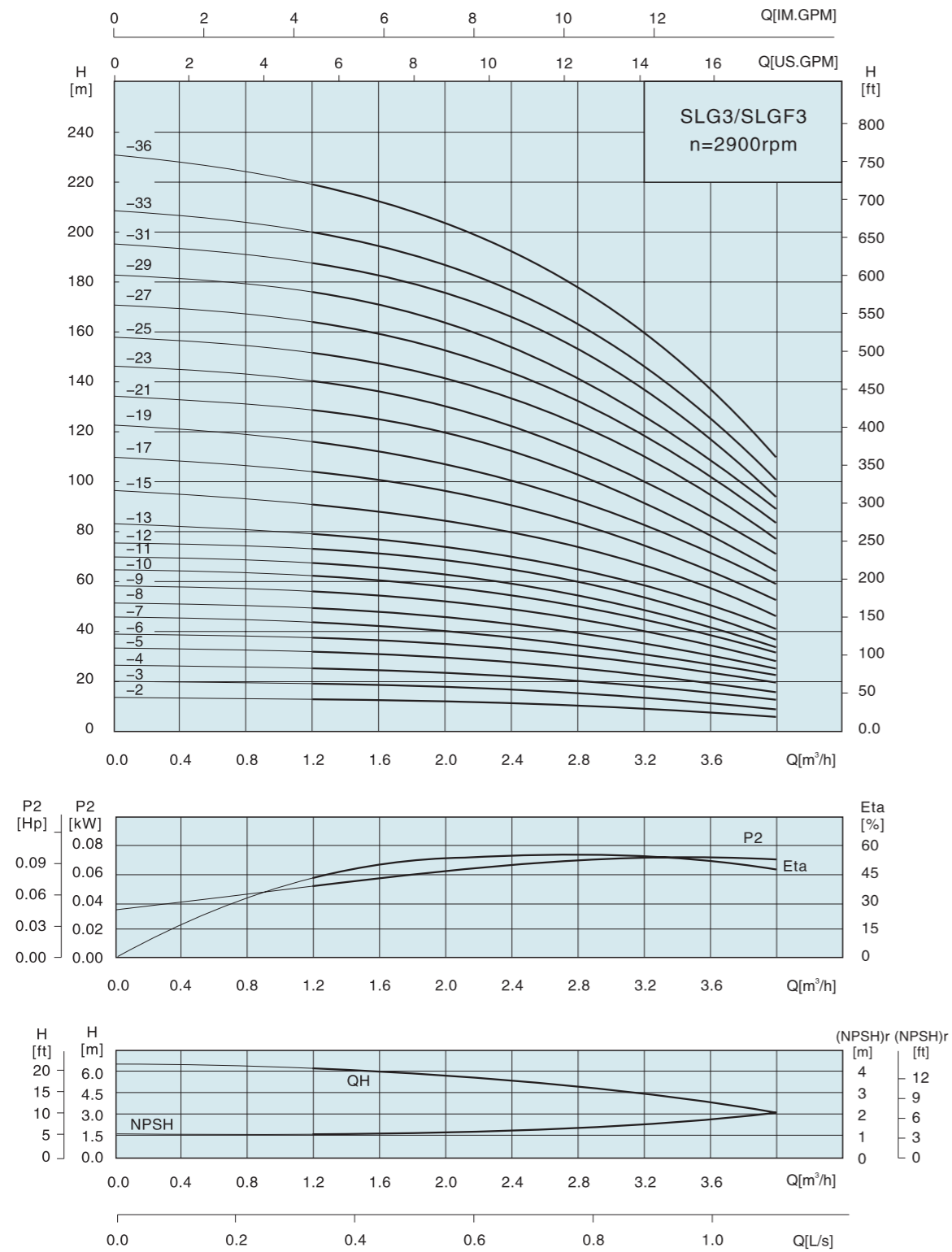

性能表及安装尺寸图表 Performance table and installation dimension

型号 Type	配用电机 Motor (kW)	Q (m³/h)	1.2	1.6	2.0	2.4	2.8	3.0	3.2	3.6	4.0
SLG3-2	0.37	H	12.5	11.5	11	10.5	10	9	8	7	6
SLG3-3	0.37	H	19	18.5	17.5	16.5	15	14	13	11	9
SLG3-4	0.37	H	25	24	23	21.5	20	19	18	15	12
SLG3-5	0.37	H	31	30	29	27	25	23	22	19	16
SLG3-6	0.55	H	36	35	34	32	30	28	27	23	19
SLG3-7	0.55	H	43	41	39	37	34	32	31	27	22
SLG3-8	0.75	H	49	47	45	43	39	37	35	31	25
SLG3-9	0.75	H	55	53	51	48	45	42	40	35	28
SLG3-10	0.75	H	61	59	57	54	50	47	45	39	31
SLG3-11	1.1	H	67	64	61	58	54	51	49	42	34
SLG3-12	1.1	H	73	70	67	63	58	55	52	45	37
SLG3-13	1.1	H	78	76	73	69	64	60	57	49	40
SLG3-15	1.1	H	90	88	84	79	73	69	66	57	46
SLG3-17	1.5	H	103	100	96	90	83	79	75	64	52
SLG3-19	1.5	H	115	112	107	100	92	88	83	72	58
SLG3-21	2.2	H	128	124	119	112	102	98	91	79	64
SLG3-23	2.2	H	140	135	130	122	112	107	100	86	70
SLG3-25	2.2	H	151	147	141	131	122	116	109	94	76
SLG3-27	2.2	H	164	159	152	143	132	124	117	101	82
SLG3-29	2.2	H	175	170	163	153	142	133	126	109	88
SLG3-31	3.0	H	187	182	175	165	153	142	135	116	94
SLG3-33	3.0	H	199	194	187	176	163	151	145	125	100
SLG3-36	3.0	H	218	212	204	192	178	168	159	137	109

安装图 Installation drawing

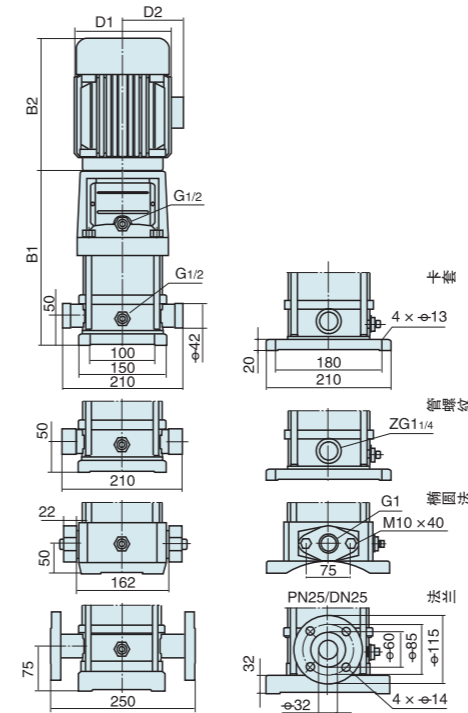

尺寸和重量 Dimension and weight

型号 Type	尺寸 Dimension (mm)					重量 Weight (kg)
	B1	B2	B1+B2	D1	D2	
SLG3-2	258	210	468	148	117	20
SLG3-3	276	210	486	148	117	20
SLG3-4	294	210	504	148	117	20
SLG3-5	312	210	522	148	117	20
SLG3-6	330	210	540	148	117	22
SLG3-7	348	210	558	148	117	22
SLG3-8	376	245	621	170	142	22
SLG3-9	394	245	639	170	142	22
SLG3-10	412	245	657	170	142	22
SLG3-11	430	245	675	170	142	25
SLG3-12	448	245	693	170	142	25
SLG3-13	466	245	711	170	142	25
SLG3-15	502	245	747	170	142	25
SLG3-17	548	290	838	190	155	30
SLG3-9	584	290	874	190	155	35
SLG3-21	620	290	910	190	155	35
SLG3-23	656	290	946	190	155	40
SLG3-25	692	290	982	190	155	40
SLG3-27	728	290	1018	190	155	40
SLG3-29	764	290	1054	190	155	40
SLG3-31	810	315	1125	197	165	45
SLG3-33	846	315	1161	197	165	50
SLG3-36	900	315	1215	197	165	50

SLG3-25~3-36无椭圆法兰型管路连接
单相电机、隔爆电机外形尺寸有所变动，详情请咨询本公司。

There are variations with SLG3-25~3-36 non-elliptical flange pipeline link and the out-form dimensions of single-phase motor and explosion-isolating motor, please consult this Co. for the details.

性能曲线 Performance curve

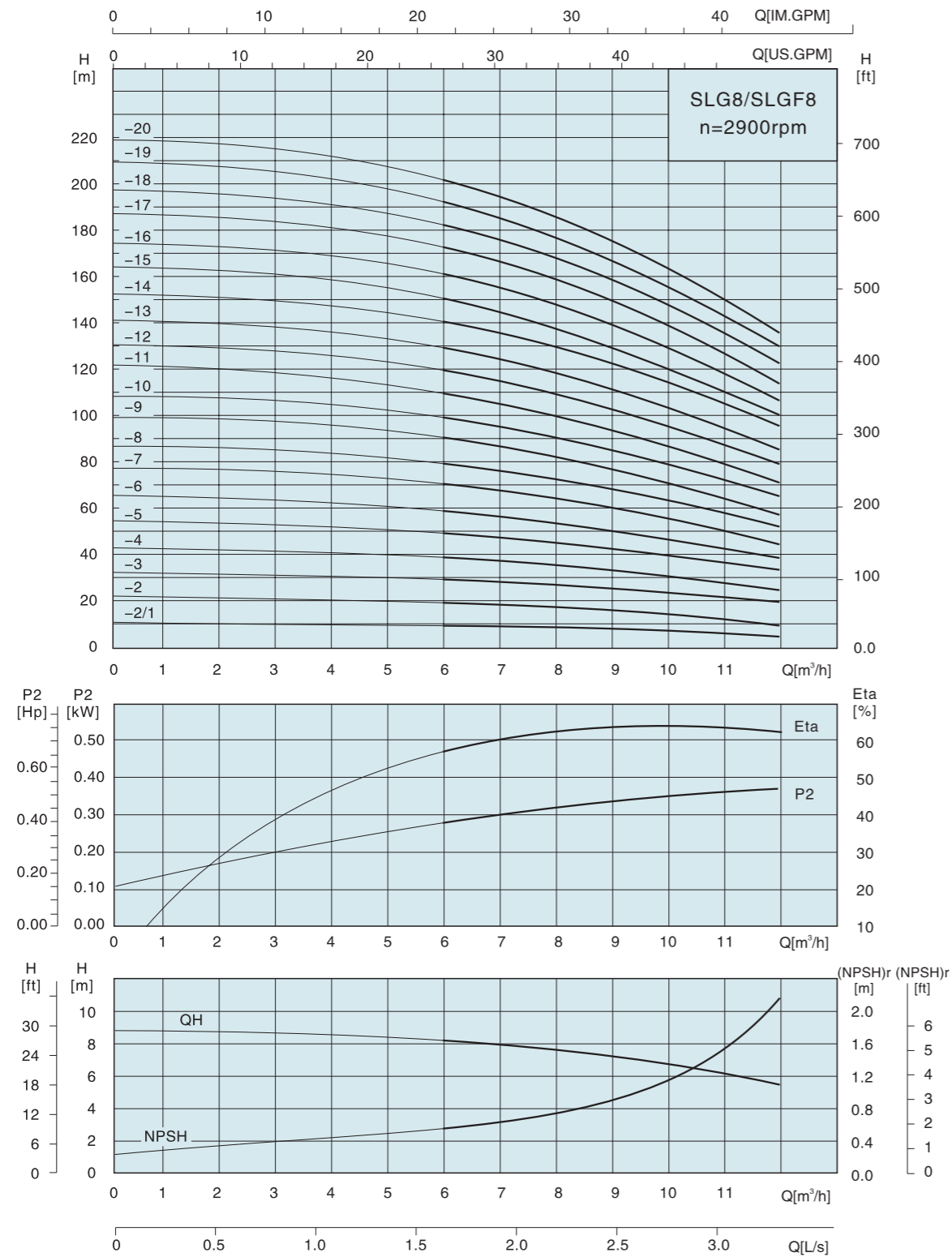

性能表及安装尺寸图表 Performance table and installation dimension

型号 Type	配用电机 Motor (kW)	Q (m³/h)	5	6	7	8	9	10	11	12
SLG8-2/1	0.75		10	9.5	9.3	9	8.5	8	7	6
SLG8-2	0.75		20	19.5	19	18	17	16	14	13
SLG8-3	1.1		30	29.5	28.5	27	25	24	21	19
SLG8-4	1.5		41	39.5	38	36	34	32	28	26
SLG8-5	2.2		52	50	48	45	42	40	36	32
SLG8-6	2.2		62	60	57	54	51	48	43	39
SLG8-8	3.0		83	80	77	73	69	65	58	52
SLG8-10	4.0		104	100	97	92	87	81	73	65
SLG8-12	4.0		124	120	116	111	104	92	87	78
SLG8-14	5.5		145	141	136	130	122	113	102	92
SLG8-16	5.5		166	161	156	148	139	130	118	106
SLG8-18	7.5		187	182	175	167	157	146	134	120
SLG8-20	7.5		208	202	195	186	175	163	150	135

安装图 Installation drawing

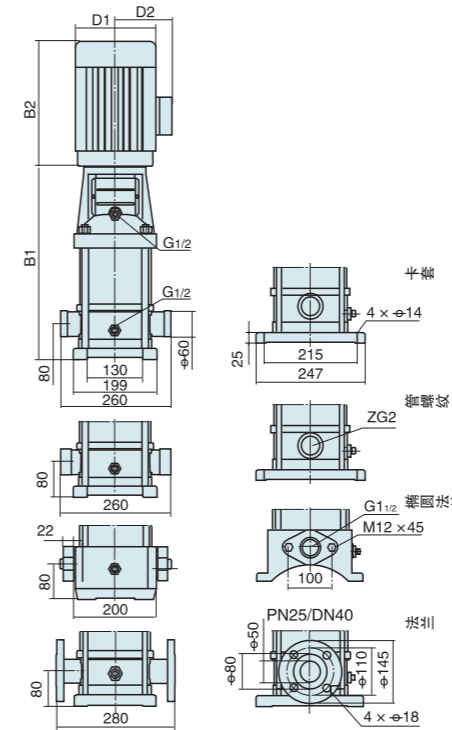

尺寸和重量 Dimension and weight

型号 Type	尺寸 Dimension (mm)					重量 Weight (kg)
	B1	B2	B1+B2	D1	D2	
SLG8-2/1	347	245	592	170	142	22
SLG8-2	347	245	592	170	142	22
SLG8-3	377	245	622	170	142	32
SLG8-4	417	290	707	190	155	32
SLG8-5	447	290	737	190	155	42
SLG8-6	477	290	767	190	155	42
SLG8-8	547	315	862	197	165	47
SLG8-10	607	335	942	230	188	57
SLG8-12	667	335	1002	230	188	57
SLG8-14	747	430	1177	260	208	82
SLG8-16	807	430	1237	260	208	82
SLG8-18	867	430	1297	260	208	92
SLG8-20	927	430	1357	260	208	92

SLG8-14~8-20无椭圆法兰型管路连接
单相电机、隔爆电机外形尺寸有所变动，详情请咨询本公司。

There are variations with SLG8-14~8-20 non-elliptical flange pipeline link and the out-form dimensions of single-phase motor and explosion-isolating motor, please consult this Co. for the details.

性能曲线 Performance curve

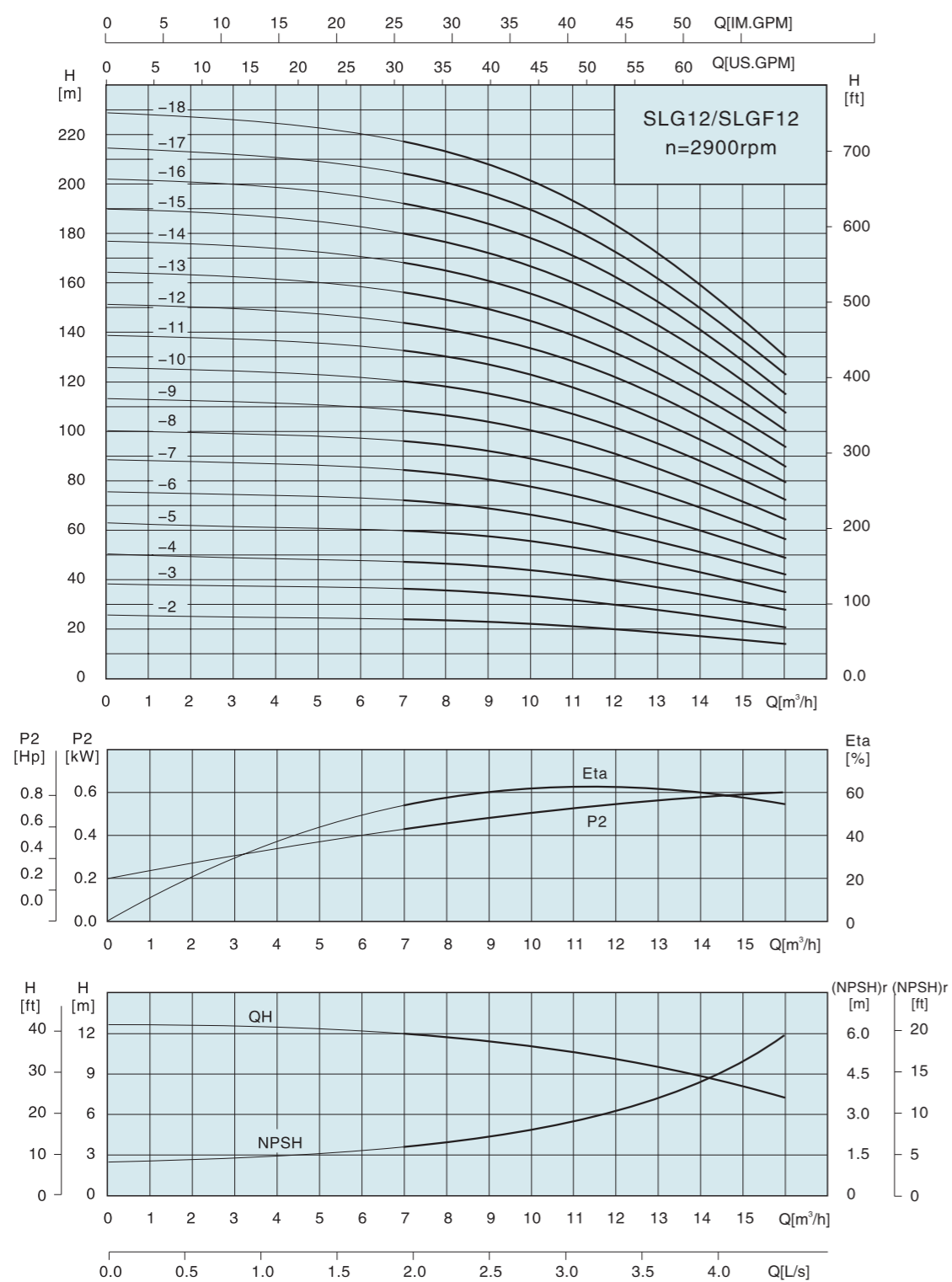

性能表及安装尺寸图表 Performance table and installation dimension

型号 Type	配用电机 Motor (kW)	Q (m³/h)	7	8	9	10	11	12	13	14	15	16
SLG12-2	1.5	H (m)	23.5	23	22.5	22	21	20	18.5	17	15.5	14
SLG12-3	2.2		35.5	35	34	33	31.5	30	28	26	23.5	21
SLG12-4	3		47	46	45	44	42	40	37	34	31	28
SLG12-5	3		59.5	58	56.5	55	52.5	50	46.5	43	39	35
SLG12-6	4		71.5	70	68	66	63	60	56	52	47	42
SLG12-7	5.5		83.5	82	79.5	77	73.5	70	65.5	61	55	49
SLG12-8	5.5		95.5	94	91	88	84	80	75	70	63	56
SLG12-9	5.5		108	106	103	100	95.5	91	85	79	71.5	64
SLG12-10	7.5		120	118	114.5	111	106	101	94.5	88	80	72
SLG12-12	7.5		143.5	141	137	133	127	121	113.5	106	96	86
SLG12-14	11		168	165	160	155	148	141	132.5	124	112	100
SLG12-16	11		192.5	189	183.5	178	170	162	152	142	128.5	115
SLG12-18	11		217	213	207.5	202	192.5	183	171.5	160	145	130

安装图 Installation drawing

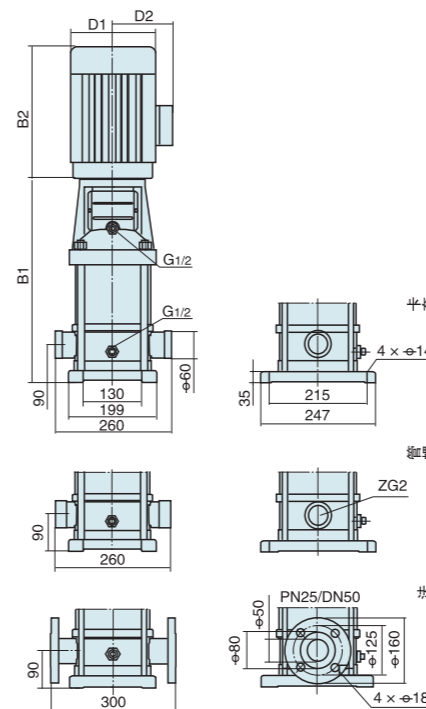

尺寸和重量 Dimension and weight

型号 Type	尺寸 Dimension (mm)					重量 Weight (kg)
	B1	B2	B1+B2	D1	D2	
SLG12-2	367	290	657	190	155	36
SLG12-3	397	290	687	190	155	39
SLG12-4	437	315	752	197	165	46
SLG12-5	467	315	782	197	165	47
SLG12-6	497	335	832	230	188	57
SLG12-7	547	430	977	260	208	75
SLG12-8	577	430	1007	260	208	75
SLG12-9	607	430	1037	260	208	77
SLG12-10	637	430	1067	260	208	77
SLG12-12	697	430	1127	260	208	79
SLG12-14	845	490	1335	330	255	150
SLG12-16	905	490	1395	330	255	150
SLG12-18	965	490	1455	330	255	152

单相电机、防爆电机外形尺寸有所变动，详情请咨询本公司。

The out-form dimensions of single-phase motor and explosion-isolating motor, please consult this Co. for the details.

性能曲线 Performance curve

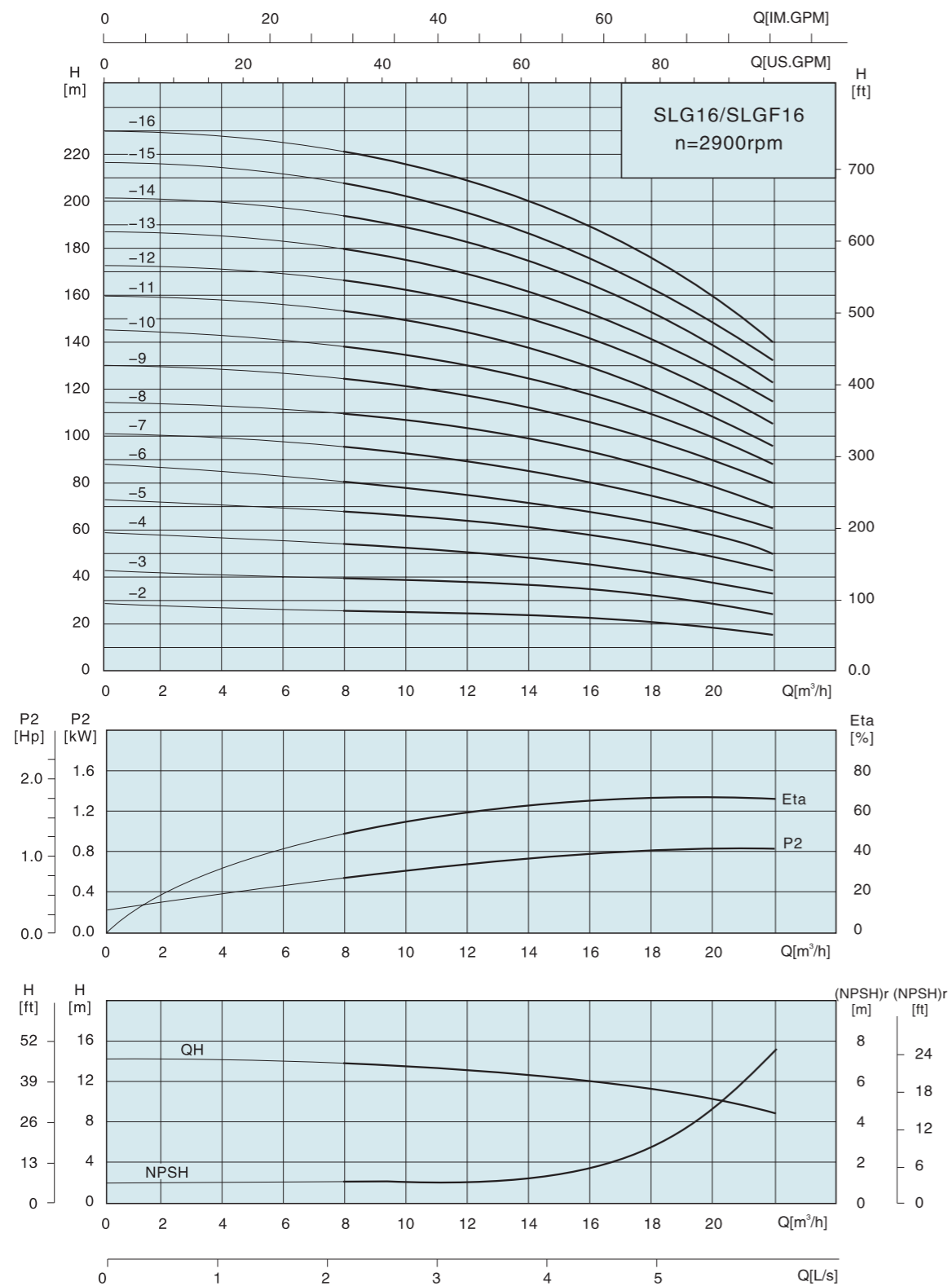

性能表及安装尺寸图表 Performance table and installation dimension

型号 Type	配用电机 Motor (kW)	Q (m³/h)	8	10	12	14	16	18	20	22
SLG16-2	2.2	H (m)	27	26	25	24	22	21	19	16
SLG16-3	3.0		41	40	38	37	34	32	29	25
SLG16-4	4.0		54	53	52	49	46	43	38	34
SLG16-5	5.5		68	67	65	62	58	54	48	43
SLG16-6	5.5		82	80	78	74	70	64	58	52
SLG16-7	7.5		96	95	91	87	82	76	68	61
SLG16-8	7.5		110	108	104	99	94	86	77	70
SLG16-10	11		138	136	131	125	118	109	97	87
SLG16-12	11		166	162	157	150	141	130	116	105
SLG16-14	15		194	190	184	175	166	152	136	122
SLG16-16	15		222	217	210	200	189	174	156	140

安装图 Installation drawing

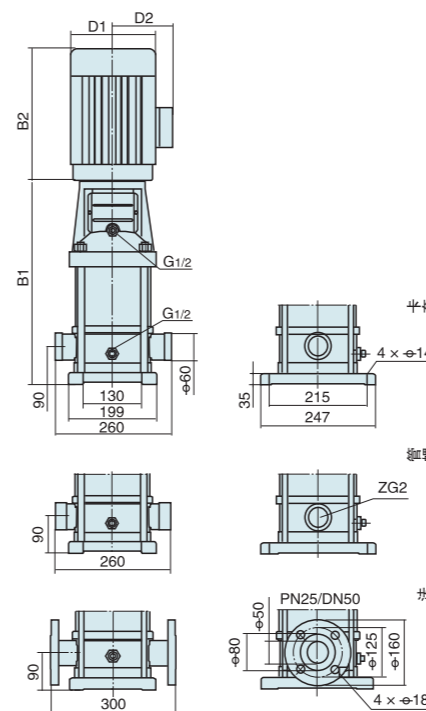

单相电机、防爆电机外形尺寸有所变动，详情请咨询本公司。

尺寸和重量 Dimension and weight

型号 Type	尺寸 Dimension (mm)					重量 Weight (kg)
	B1	B2	B1+B2	D1	D2	
SLG16-2	397	290	687	190	155	42
SLG16-3	452	315	767	197	165	52
SLG16-4	497	335	832	230	188	57
SLG16-5	562	430	992	260	208	72
SLG16-6	607	430	1037	260	208	77
SLG16-7	652	430	1082	260	208	82
SLG16-8	697	430	1127	260	208	82
SLG16-10	875	490	1365	330	255	142
SLG16-12	965	490	1455	330	255	147
SLG16-14	1055	490	1545	330	255	162
SLG16-16	1145	490	1635	330	255	167

The out-form dimensions of single-phase motor and explosion-isolating motor, please consult this Co. for the details.

性能曲线 Performance curve

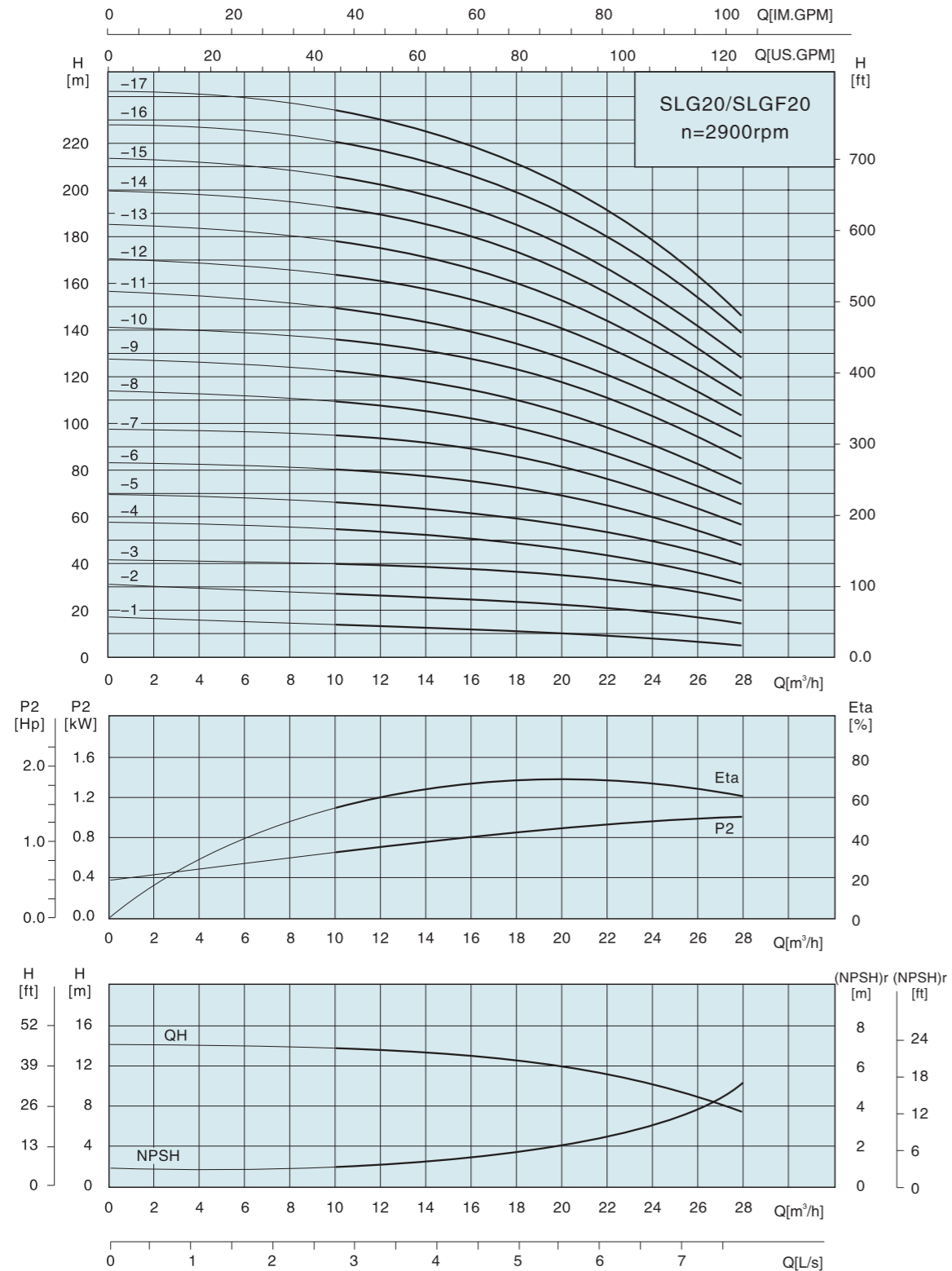

性能表及安装尺寸图表 Performance table and installation dimension

型号 Type	配用电机 Motor (kW)	Q (m³/h)	10	12	14	16	18	20	22	24	26	28
SLG20-1	1.1	H (m)	13.5	13	12.5	12	11	10	9	8	7	6
SLG20-2	2.2		27	26.5	26	25	24	23	22	20	18	15
SLG20-3	4.0		40	39.5	39	38	37	35	33	30	27	24
SLG20-4	5.5		54	53	52	51	49	47	44	41	37	33
SLG20-5	5.5		67	66	64	62	60	58	55	50	45	40
SLG20-6	7.5		81	79	77	75	73	70	66	61	55	49
SLG20-7	7.5		95	93	91	89	86	82	77	71	65	58
SLG20-8	11		109	107	105	102	99	94	89	82	75	67
SLG20-10	11		136	134	131	128	124	118	111	103	95	85
SLG20-12	15		164	162	158	154	149	142	133	124	114	102
SLG20-14	15		192	189	185	180	174	166	156	145	133	119
SLG20-17	18.5		234	230	225	219	212	202	190	177	162	145

安装图 Installation drawing

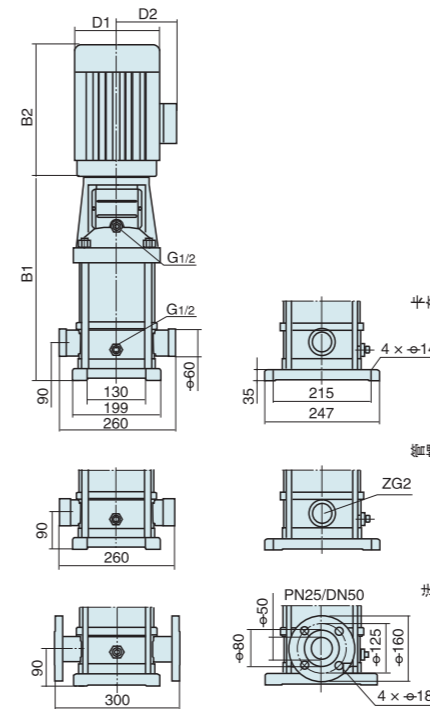

尺寸和重量 Dimension and weight

型号 Type	尺寸 Dimension (mm)					重量 Weight (kg)
	B1	B2	B1+B2	D1	D2	
SLG20-1	387	245	632	170	142	32
SLG20-2	397	290	687	190	155	43
SLG20-3	452	335	787	230	188	57
SLG20-4	517	430	947	260	208	72
SLG20-5	562	430	992	260	208	74
SLG20-6	607	430	1037	260	208	82
SLG20-7	652	430	1082	260	208	84
SLG20-8	785	490	1275	330	255	140
SLG20-10	875	490	1365	330	255	145
SLG20-12	965	490	1455	330	255	160
SLG20-14	1055	490	1545	330	255	165
SLG20-17	1190	550	1740	330	255	190

单相电机、防爆电机外形尺寸有所变动，详情请咨询本公司。

The out-form dimensions of single-phase motor and explosion-isolating motor, please consult this Co. for the details.

性能曲线 Performance curve

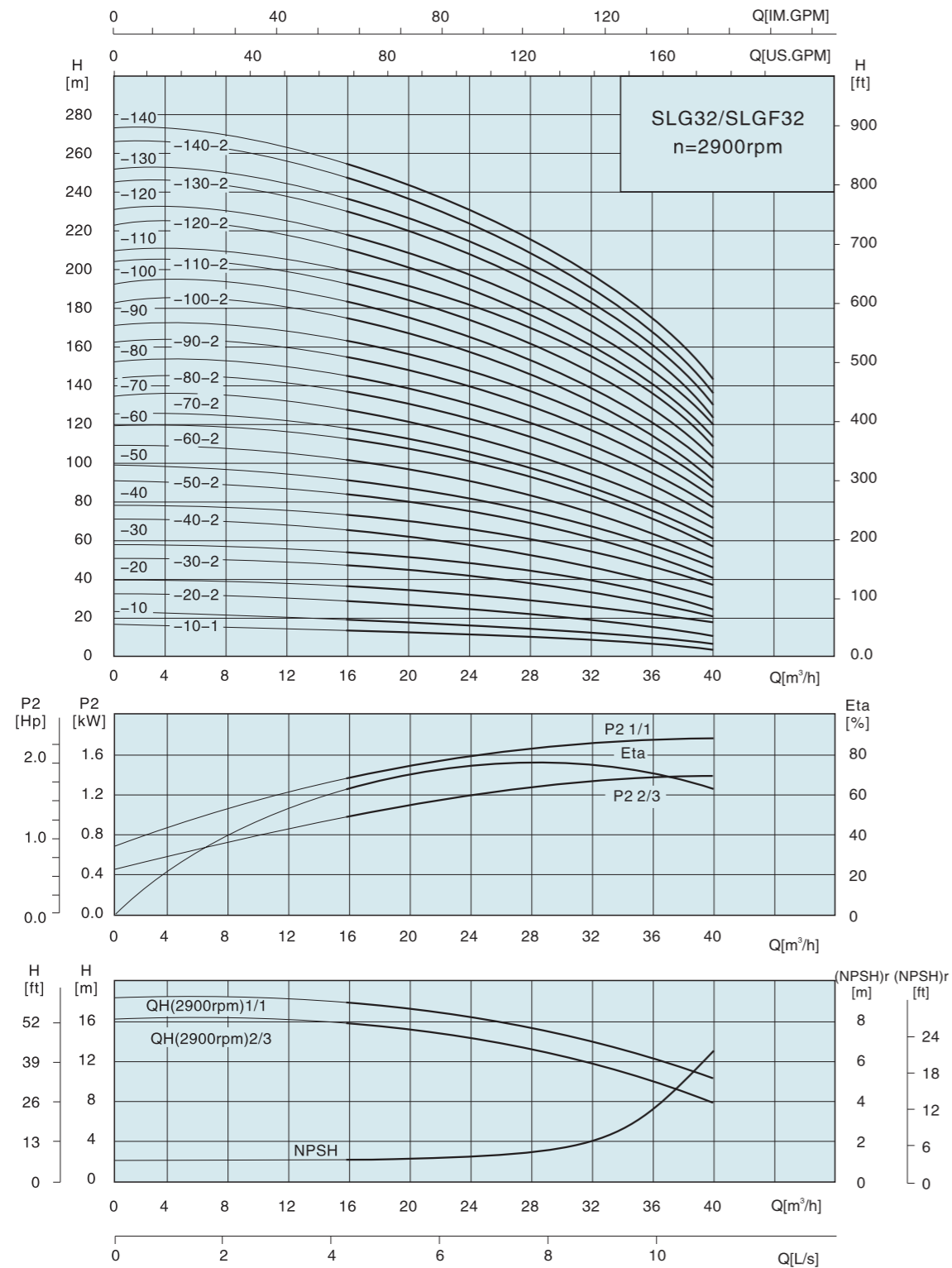

性能表及安装尺寸图表 Performance table and installation dimension

型号 Type	配用电机 Motor (kW)	Q (m³/h)	16	20	24	28	32	36	40
SLG32-10-1	1.5	H (m)	14	13	12	11	9	7	4
SLG32-10	2.2		18	17	15	14	13	11	8
SLG32-20-2	3.0		29	28	26	23	20	16	11
SLG32-20	4.0		36	34	32	29	27	23	18
SLG32-30-2	5.5		47	44	41	38	33	28	21
SLG32-30	5.5		54	51	48	44	40	35	27
SLG32-40-2	7.5		65	62	58	53	46	40	30
SLG32-40	7.5		72	69	65	59	53	47	37
SLG32-50-2	11		83	79	74	68	60	52	41
SLG32-50	11		90	86	81	74	67	59	47
SLG32-60-2	11		101	97	90	83	74	65	51
SLG32-60	11		108	104	97	90	81	72	57
SLG32-70-2	15		119	114	107	98	88	78	60
SLG32-70	15		126	121	113	105	95	85	67

型号 Type	配用电机 Motor (kW)	Q (m³/h)	16	20	24	28	32	36	40
SLG32-80-2	15	H (m)	136	131	123	114	102	90	71
SLG32-80	15		144	138	130	120	109	97	77
SLG32-90-2	18.5		154	148	140	129	117	102	82
SLG32-90	18.5		162	156	147	136	124	109	88
SLG32-100-2	18.5		175	166	157	146	131	115	91
SLG32-100	18.5		182	173	164	152	138	122	98
SLG32-110-2	22		193	184	173	164	146	128	102
SLG32-110	22		200	191	180	168	153	135	109
SLG32-120-2	22		211	201	189	178	160	140	113
SLG32-120	22		218	208	196	184	167	147	120
SLG32-130-2	30		230	218	206	193	174	153	124
SLG32-130	30		237	225	213	200	181	160	131
SLG32-140-2	30		247	235	222	210	189	165	135
SLG32-140	30		255	242	229	216	196	172	142

安装图 Installation drawing

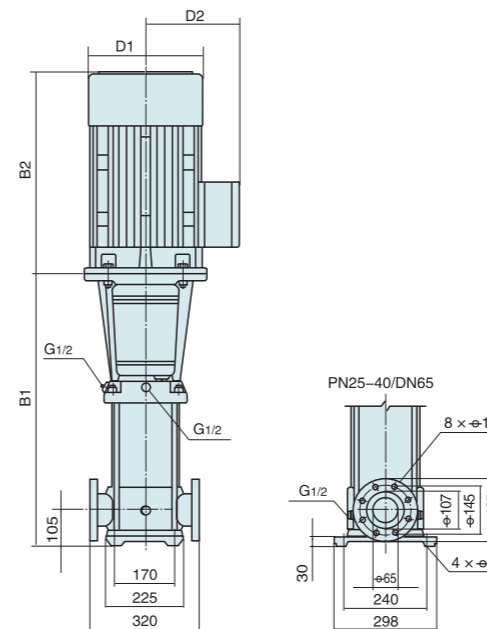

单相电机、防爆电机外形尺寸有所变动，详情请咨询本公司。

尺寸和重量 Dimension and weight

型号 Type	尺寸 Dimension (mm)					重量 Weight (kg)
	B1	B2	B1+B2	D1	D2	
SLG32-10-1/SLG32-10	505	290	795	190	155	68/71
SLG32-20-2/SLG32-20	575	315/335	890/910	197/230	165/180	78/84
SLG32-30-2/SLG32-30	645	430	1075	260	208	93
SLG32-40-2/SLG32-40	715	430	1145	260	208	102
SLG32-50-2/SLG32-50	890	490	1380	330	255	172
SLG32-60-2/SLG32-60	960	490	1450	330	255	176
SLG32-70-2/SLG32-70	1030	490	1520	330	255	188
SLG32-80-2/SLG32-80	1100	490	1590	330	255	192
SLG32-90-2/SLG32-90	1170	550	1720	330	255	218
SLG32-100-2/SLG32-100	1240	550	1790	330	255	222
SLG32-110-2/SLG32-110	1310	590	1900	360	285	259
SLG32-120-2/SLG32-120	1380	590	1970	360	285	263
SLG32-130-2/SLG32-130	1450	660	2110	400	310	327
SLG32-140-2/SLG32-140	1520	660	2180	400	310	331

The out-form dimensions of single-phase motor and explosion-isolating motor, please consult this Co. for the details.

性能曲线 Performance curve

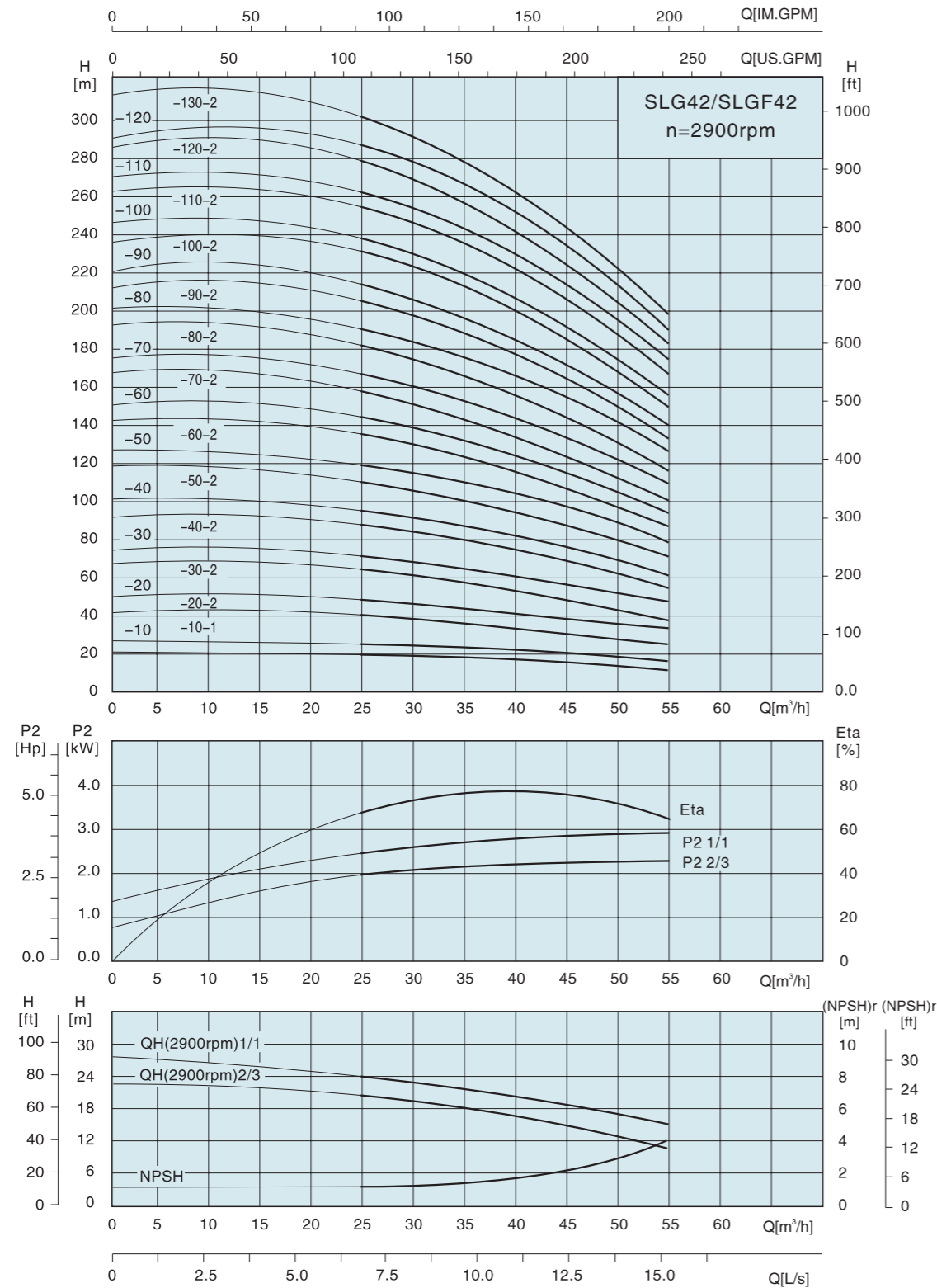

性能表及安装尺寸图表 Performance table and installation dimension

型号 Type	配用电机 Motor (kW)	Q (m³/h)	25	30	35	40	42	45	50	55
SLG42-10-1	3.0		20	19	18	17	16	15	13	11
SLG42-10	4.0		24	23	22	21	20	19	18	16
SLG42-20-2	5.5		40	38	36	33	32	30	27	23
SLG42-20	7.5		48	46	44	42	41	39	35	31
SLG42-30-2	11		63	61	58	54	52	50	44	38
SLG42-30	11		71	69	66	63	61	58	53	47
SLG42-40-2	15		87	84	80	75	73	69	62	54
SLG42-40	15		95	92	88	84	81	78	71	62
SLG42-50-2	18.5		111	107	102	96	93	88	80	69
SLG42-50	18.5		119	115	110	105	101	97	88	78
SLG42-60-2	22		135	130	124	117	113	108	97	85
SLG42-60	22		143	138	132	125	122	116	106	93
SLG42-70-2	30		158	152	146	138	134	127	115	100
SLG42-70	30		166	161	154	146	142	135	124	109
SLG42-80-2	30		182	175	168	159	154	146	133	116
SLG42-80	30		190	184	176	167	162	154	141	124
SLG42-90-2	30		205	198	190	180	174	166	150	132
SLG42-90	37		214	207	198	188	183	174	159	140
SLG42-100-2	37		230	221	212	200	194	185	168	147
SLG42-100	37		238	230	220	209	203	193	177	155
SLG42-110-2	45		255	246	236	223	217	206	188	165
SLG42-110	45		263	255	244	232	225	214	196	173
SLG42-120-2	45		280	270	259	245	238	226	206	181
SLG42-120	45		289	280	268	255	247	236	216	190
SLG42-130-2	45		305	294	282	267	259	247	225	198

安装图 Installation drawing

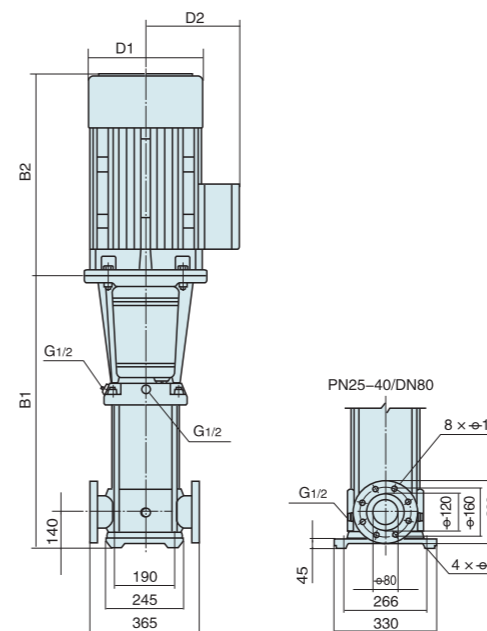

尺寸和重量 Dimension and weight

型号 Type	尺寸 Dimension (mm)					重量 Weight (kg)
	B1	B2	B1+B2	D1	D2	
SLG42-10-1						
SLG42-10	561	315/335	876/896	197/230	165/188	86/92
SLG42-20-2						
SLG42-20	641	430	1071	260	208	102/107
SLG42-30-2						
SLG42-30	826	490	1316	330	255	175
SLG42-40-2						
SLG42-40	906	490	1396	330	255	187
SLG42-50-2						
SLG42-50	986	550	1536	330	255	208
SLG42-60-2						
SLG42-60	1066	590	1656	360	285	251
SLG42-70-2						
SLG42-70	1146	660	1806	400	310	315
SLG42-80-2						
SLG42-80	1226	660	1886	400	310	319
SLG42-90-2						
SLG42-90	1306	660	1966	400	310	323/343
SLG42-100-2						
SLG42-100	1386	660	2046	400	310	347
SLG42-110-2						
SLG42-110	1466	700	2166	450	345	413
SLG42-120-2						
SLG42-120	1546	700	2246	450	345	417
SLG42-130-2						
SLG42-130	1626	700	2326	450	345	421

单相电机、防爆电机外形尺寸有所变动，详情请咨询本公司。

The out-form dimensions of single-phase motor and explosion-isolating motor, please consult this Co. for the details.

性能曲线 Performance curve

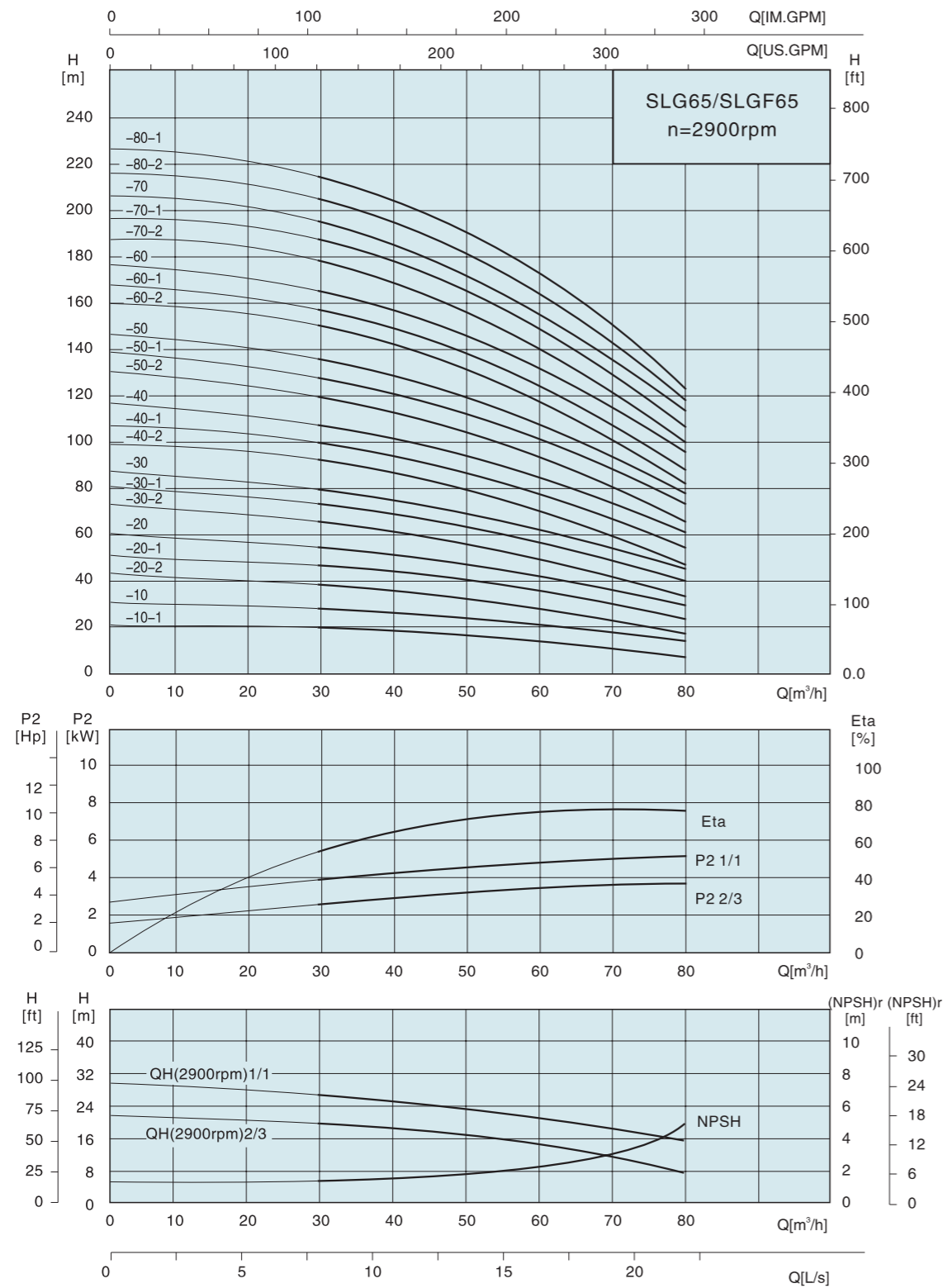

性能表及安装尺寸图表 Performance table and installation dimension

型号 Type	配用电机 Motor (kW)	Q (m³/h)	30	40	50	60	65	70	80
SLG65-10-1	4.0	H (m)	19	18	16	14	13	11	8
SLG65-10	5.5		27	25	23	21	20	18	15
SLG65-20-2	7.5		39	36	33	29	26	23	17
SLG65-20-1	11		46	44	40	36	33	30	24
SLG65-20	11		53	51	47	43	40	37	30
SLG65-30-2	15		66	62	56	50	46	41	32
SLG65-30-1	15		73	69	63	57	53	48	39
SLG65-30	18.5		80	76	70	64	60	55	46
SLG65-40-2	18.5		92	87	80	71	66	60	47
SLG65-40-1	22		100	94	87	78	73	67	54
SLG65-40	22		107	101	94	85	80	74	61
SLG65-50-2	30		121	114	105	95	88	80	64
SLG65-50-1	30		128	121	112	102	95	87	71
SLG65-50	30		136	129	119	109	102	94	78
SLG65-60-2	30		150	142	131	118	110	101	81
SLG65-60-1	37		157	149	138	125	117	108	88
SLG65-60	37		164	156	145	132	124	115	95
SLG65-70-2	37		179	169	156	141	132	121	99
SLG65-70-1	37		186	176	163	148	139	128	106
SLG65-70	45		193	183	170	155	146	135	112
SLG65-80-2	45	207	196	182	164	154	142	116	
SLG65-80-1	45	215	203	189	171	161	149	123	

安装图 Installation drawing

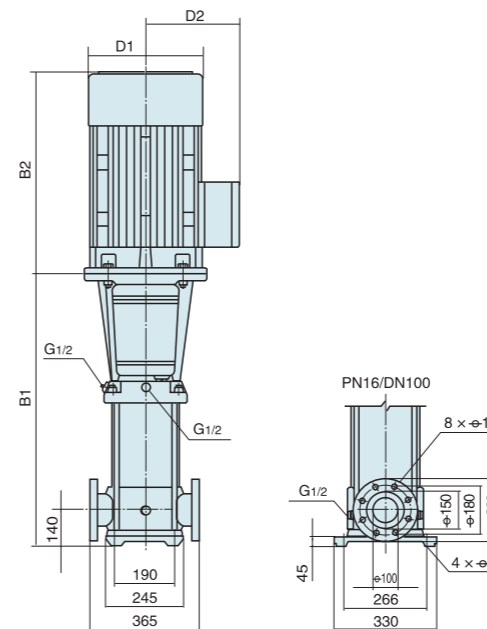

尺寸和重量 Dimension and weight

型号 Type	尺寸 Dimension (mm)					重量 Weight (kg)
	B1	B2	B1+B2	D1	D2	
SLG65-10-1	561	335	896	230	188	105
SLG65-10	561	430	991	260	208	110
SLG65-20-2	644	430	1074	260	208	120
SLG65-20-1	754	490	1244	330	255	155
SLG65-20	754	490	1244	330	255	155
SLG65-30-2	836	490	1326	330	255	195
SLG65-30-1	836	490	1326	330	255	195
SLG65-30	836	550	1386	330	255	205
SLG65-40-2	919	550	1469	330	255	208
SLG65-40-1	919	590	1509	360	285	260
SLG65-40	919	590	1509	360	285	260
SLG65-50-2	1001	660	1661	400	310	345
SLG65-50-1	1001	660	1661	400	310	345
SLG65-50	1001	660	1661	400	310	345
SLG65-60-2	1084	660	1744	400	310	350
SLG65-60-1	1084	660	1744	400	310	370
SLG65-60	1084	660	1744	400	310	370
SLG65-70-2	1166	660	1826	400	310	375
SLG65-70-1	1166	660	1826	400	310	375
SLG65-70	1166	700	1866	460	340	435
SLG65-80-2	1248	700	1948	460	340	440
SLG65-80-1	1248	700	1948	460	340	440

单相电机、防爆电机外形尺寸有所变动，详情请咨询本公司。该系列也可按客户要求提供PN25/DN100标准法兰。

The out-form dimensions of single-phase motor and explosion-isolating motor, please consult this Co. for the details. For this series, PN25/DN100 standard flange can also be supplied if so required by users.

性能曲线 Performance curve

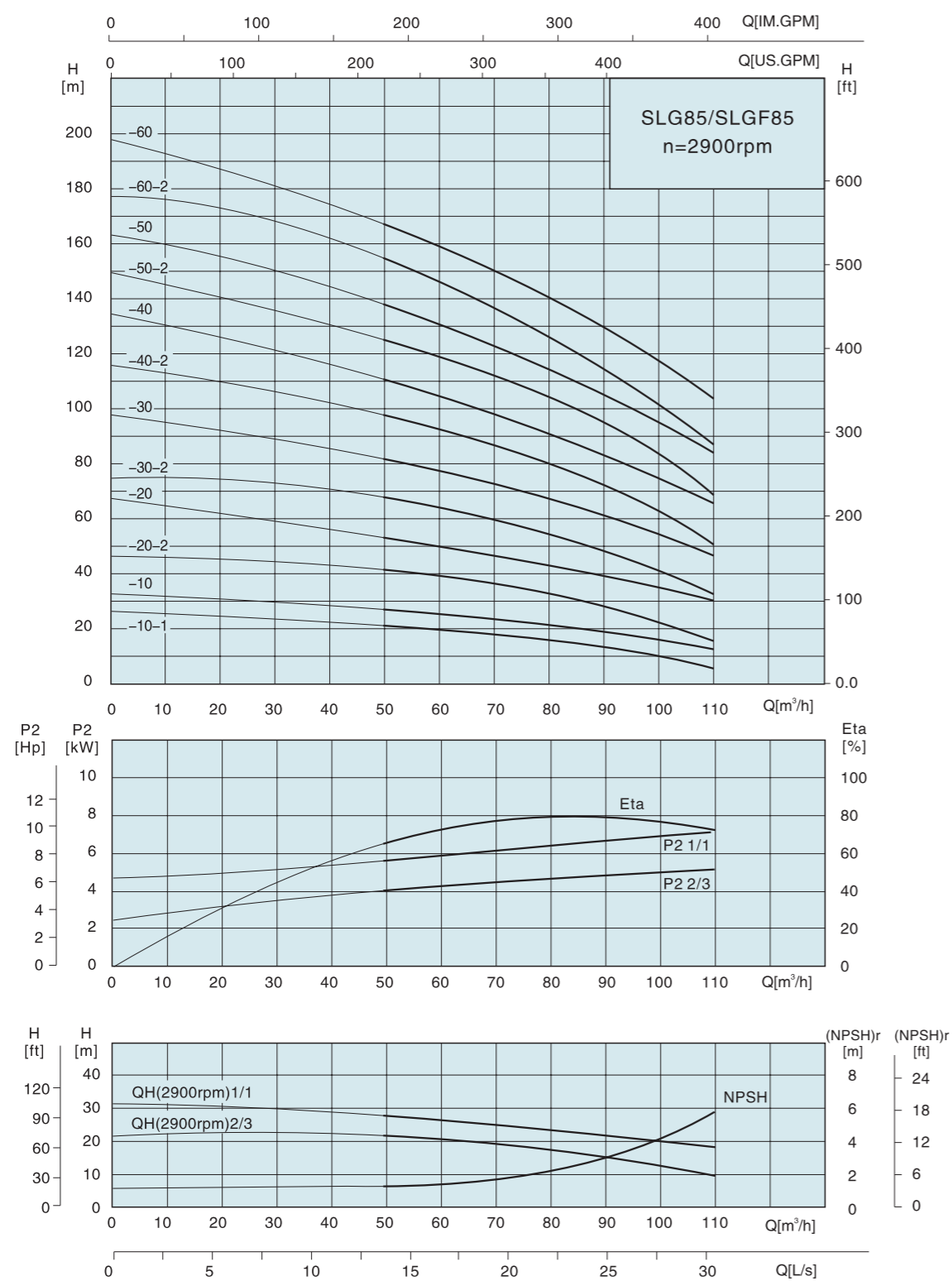

性能表及安装尺寸图表 Performance table and installation dimension

型号 Type	配用电机 Motor (kW)	Q (m³/h)	50	60	70	80	85	90	100	110
SLG85-10-1	5.5	H (m)	22	19	17	16	14	13	10	6
SLG85-10	7.5		25	24	22	21	20	19	16	12
SLG85-20-2	11		41	39	36	32	30	28	22	15
SLG85-20	15		53	50	47	44	41	40	36	30
SLG85-30-2	18.5		68	65	60	55	52	49	41	32
SLG85-30	22		81	77	72	67	64	62	55	48
SLG85-40-2	30		98	93	87	80	75	72	62	50
SLG85-40	30		110	105	100	92	86	84	76	66
SLG85-50-2	37		126	120	113	104	98	93	81	68
SLG85-50	37		139	131	124	115	110	106	94	83
SLG85-60-2	45		155	148	139	129	122	117	102	86
SLG85-60	45		168	160	150	141	134	130	117	103

安装图 Installation drawing

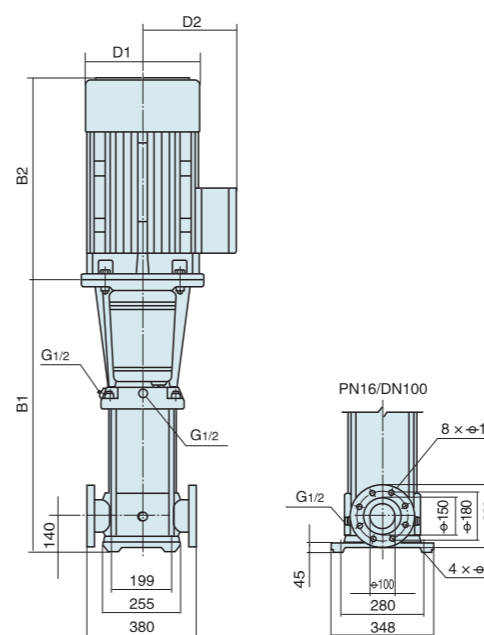

尺寸和重量 Dimension and weight

型号 Type	尺寸 Dimension (mm)					重量 Weight (kg)
	B1	B2	B1+B2	D1	D2	
SLG85-10-1	571	430	1001	260	208	120
SLG85-10	571	430	1001	260	208	122
SLG85-20-2	773	490	1263	330	255	165
SLG85-20	773	490	1263	330	255	198
SLG85-30-2	865	550	1415	330	255	212
SLG85-30	865	590	1455	360	285	265
SLG85-40-2	957	660	1617	400	310	348
SLG85-40	957	660	1617	400	310	348
SLG85-50-2	1049	660	1709	400	310	375
SLG85-50	1049	660	1709	400	310	375
SLG85-60-2	1141	700	1841	460	340	438
SLG85-60	1141	700	1841	460	340	438

单相电机、防爆电机外形尺寸有所变动，详情请咨询本公司。该系列也可按客户要求提供PN25/DN100标准法兰。

The out-form dimensions of single-phase motor and explosion-isolating motor, please consult this Co. for the details. For this series, PN25/DN100 standard flange can also be supplied if so required by users.

性能曲线 Performance curve

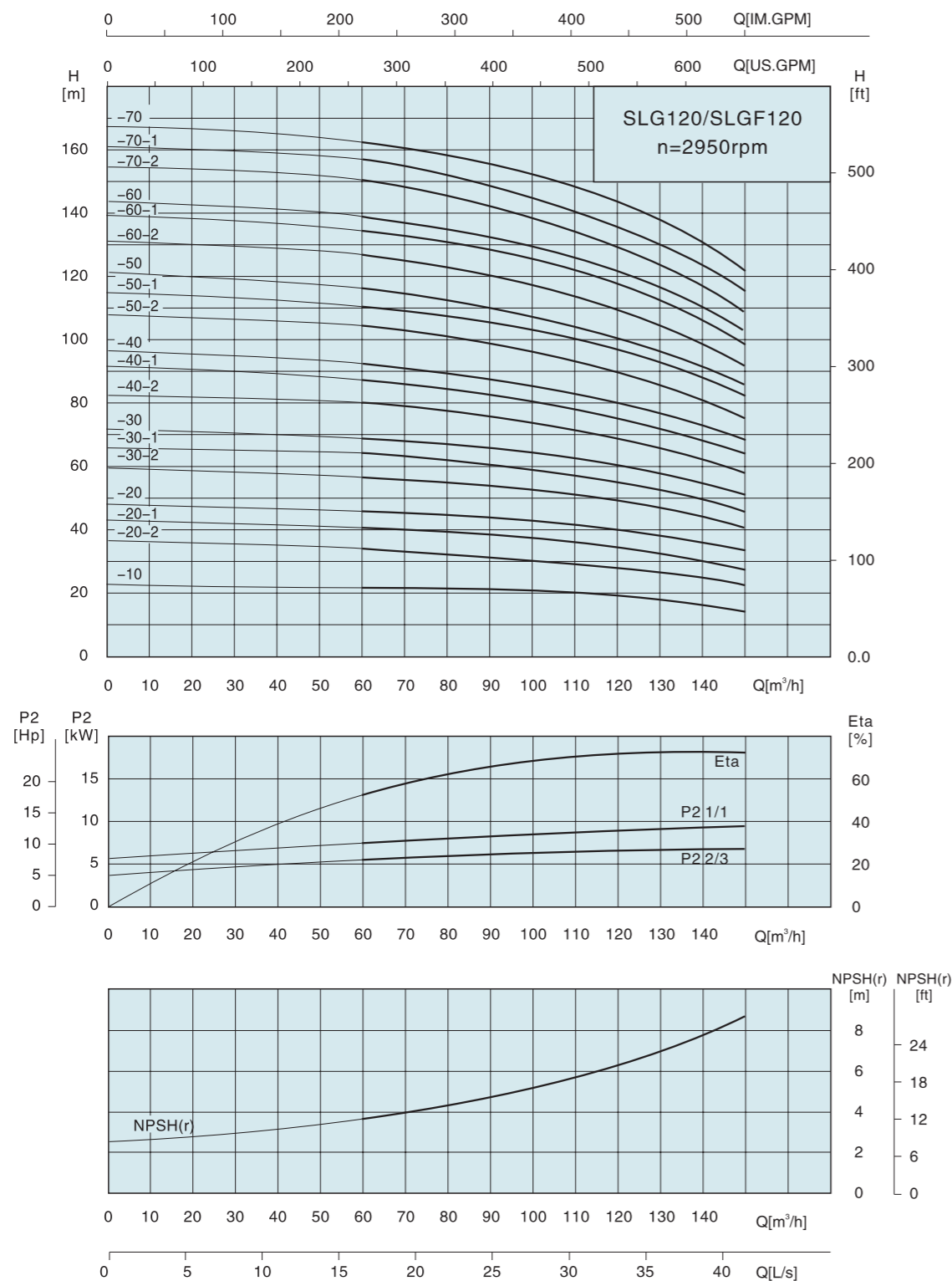

性能表及安装尺寸图表 Performance table and installation dimension

型号 Type	配用电机 Motor (kW)	Q (m³/h)	60	70	80	90	100	110	120	130	140	150
SLG120-10	11	H	22	21.8	21.6	21	20.5	19.5	18.5	17	16	15
SLG120-20-2	15	H	34	33.6	33	31	30.2	30	28.5	27	25	24
SLG120-20-1	18.5	H	41	40	39.5	38.5	37	36.5	34.5	32.5	30	27.5
SLG120-20	22	H	46	45	44.5	43.5	42.4	41	40	38	36	33.5
SLG120-30-2	30	H	57	56	55	53.5	52	51	49	46.5	43.5	41
SLG120-30-1	30	H	64	63	62	60	58.5	57.5	55.5	52	49	46
SLG120-30	30	H	69.5	68.5	67.5	66	64.4	62.5	61	57.5	54.5	51
SLG120-40-2	37	H	80.5	79	78	76	73.5	72	69	66	61.5	58
SLG120-40-1	37	H	87	86	84.5	82	80	78	76	72	68	64.5
SLG120-40	45	H	92.5	91	90	88	85.5	83	81	77	73	68.5
SLG120-50-2	45	H	104.5	103	101	99	96	93	90	85.5	80.5	75.5
SLG120-50-1	45	H	110.5	109	107.5	105	102	100	97	92	86.5	83
SLG120-50	55	H	115.5	114	113	110	107.5	104.5	101.5	96	91	86
SLG120-60-2	55	H	128	125.5	123	121	117.3	113.5	110	104.5	98.5	92.5
SLG120-60-1	55	H	134	132	130.5	127	124	121	118	111	105	100
SLG120-60	75	H	139	137	135	132	128.8	126	123	116	110	104
SLG120-70-2	75	H	151	148	145.5	143	138.6	134	130	123.5	116.5	109
SLG120-70-1	75	H	156.5	154	152	148.5	144.5	141	137.5	130	123	116.5
SLG120-70	75	H	162.5	160.5	158.5	155	151	148	145	137	129	123

安装图 Installation drawing

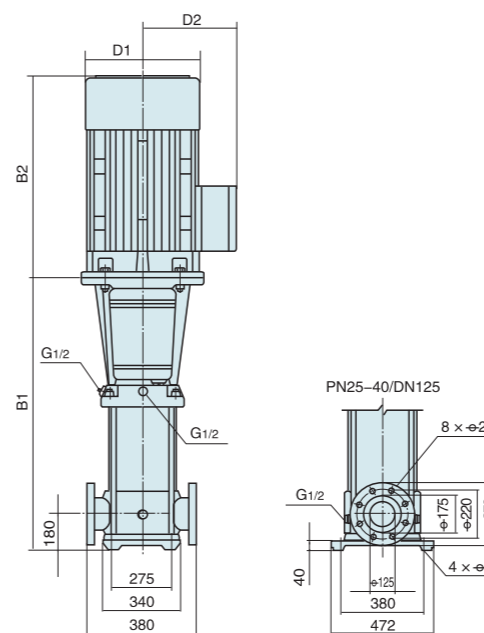

尺寸和重量 Dimension and weight

型号 Type	尺寸 Dimension (mm)					重量 Weight (kg)
	B1	B2	B1+B2	D1	D2	
SLG120-10	840	490	1330	330	255	230
SLG120-20-2	1000	490	1490	330	255	245
SLG120-20-1	1000	550	1550	330	255	250
SLG120-20	1000	590	1590	360	285	285
SLG120-30-2	1160	660	1820	400	310	360
SLG120-30-1	1160	660	1820	400	310	360
SLG120-30	1160	660	1820	400	310	360
SLG120-40-2	1320	660	1980	400	310	400
SLG120-40-1	1320	660	1980	400	310	400
SLG120-40	1320	700	2020	460	340	460
SLG120-50-2	1480	700	2180	460	340	470
SLG120-50-1	1480	700	2180	460	340	470
SLG120-50	1510	770	2280	540	370	575
SLG120-60-2	1670	770	2440	540	370	585
SLG120-60-1	1670	770	2440	540	370	585
SLG120-60	1670	845	2515	580	410	705
SLG120-70-2	1830	845	2675	580	410	715
SLG120-70-1	1830	845	2675	580	410	715
SLG120-70	1830	845	2675	580	410	715

单相电机、防爆电机外形尺寸有所变动，详情请咨询本公司。

The out-form dimensions of single-phase motor and explosion-isolating motor, please consult this Co. for the details.

典型案例 typical case enterprise class

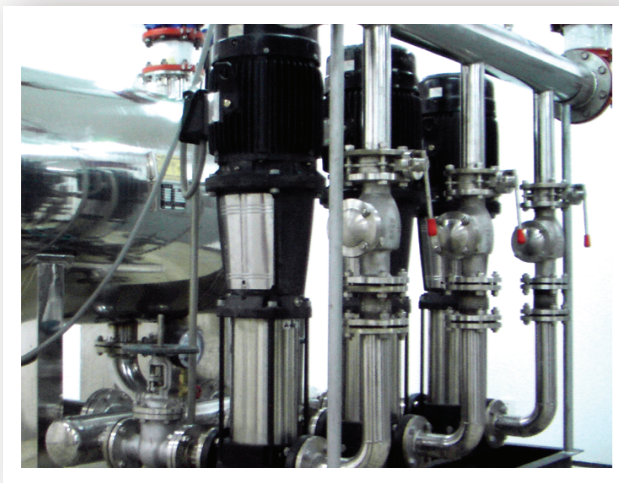

- | | | |
|-----------------|-------------------|-------------------|
| 地矿研究所 | 滁州皖东建筑防腐工程 | 辽宁能源研究所 |
| 时代大酒店 | 枣庄北斗通风设备有限公司 | 安徽省迪安房地产开发有限公司 |
| 青岛金湖热力公司 | 南京建工房地产开发有限公司 | 安徽大唐市场建设集团有限公司 |
| 烟台氨纶股份有限公司 | 宁夏红果乳业有限公司 | 中化格力高栏港石化仓储项目 |
| 南通四建设备处 | 北京万达广场二期热力工程热力交换站 | 日照铭泰房地产开发有限公司 |
| 天津钢铁有限公司 | 北京恒富家园3# | 安徽长丰海螺水泥有限公司 |
| 时代大酒店 | 宜昌市东科变频技术应用有限公司 | 日照海达机电设备有限公司 |
| 四平市巨鹏热能设备有限公司 | 北京热力公司 | 芜湖宇润实业有限公司 |
| 江苏三木集团化工厂 | 富华大厦热力站 | 北京通大华泉公司 |
| 吉林市乾源科工贸有限公司 | 沧州市银河电力有限公司 | 宣城市第三建筑公司 |
| 石嘴山金联实业有限责任公司 | 广西华盈房地产开发有限公司 | 广西壮锦房地产开发有限公司 |
| 秦皇岛市金海粮油公司 | 哈尔滨市华能集中供热有限公司 | 灵石县中煤九鑫焦化有限公司 |
| 常州市郊区建筑安装公司 | 马鞍山首创水务有限公司 | 吉林达利食品有限公司 |
| 神林电子 | 青岛黄海房地产实业有限公司 | 中国兵器工业集团 |
| 吉林晨鸣纸业集团有限公司 | 中美合资南阳鸿德房地产开发有限公司 | 潍坊开发区天齐机械设备制造销售中心 |
| 吉林草还丹药业有限公司 | 咸阳华泰房地产公司 | 漯河自来水公司 |
| 宝钢集团上海第一钢铁有限公司 | 济南金河房地产综合开发有限公司 | 中国房地产开发合肥分公司 |
| 新泰市三得染料厂 | 山东东明石化集团 | 合肥宝业房地产有限公司 |
| 天津荣安泰环保设备技术有限公司 | 山西鲁晋王曲发电有限公司 | 赤山集团有限公司 |
| 烟台氨纶股份有限公司 | 上海华东电器集团有限公司 | 芜湖富达建安公司 |
| 南通市飞力机泵销售处 | 芜湖优顺环保科技有限公司 | 津城房地产时代广场分公司 |
| 河南油田第二采油厂 | 中昊晨光化工研究院 | 日照都市花园房地产开发有限公司 |
| 金海粮油公司 | 合肥富泰房地产开发有限公司 | 中国空空导弹研究院 |
| 抚顺庆威化工有限公司 | 大理鸿元经贸有限公司 | 东方华府 |
| 福州东福实业发展有限公司 | 宝星国际 | 滁州市经济技术开发区项目建设办公室 |
| 苔原机械(上海)有限公司 | 青岛威景体育用品有限公司 | 宣城市房地产开发有限公司 |
| 广东中山市隆都发电厂有限公司 | 连云港市九龙房地产开发有限公司 | 合肥德恒置业有限公司 |
| 大成温调机电工程 | 济南泓昌科贸有限公司 | 青岛斯瑞机电设备有限公司 |
| 青岛金湖热力公司 | 胜利油田胜动集团 | 深圳市能源环保工程有限公司 |
| 中国水利电力物资西安公司 | 皖能集团 | 宜昌市东科变频技术应用有限公司 |
| 四平北方换热器有限公司 | 重庆市中科普永奥地产有限公司 | 连云港市信泰智能工程有限公司 |

服务网络

连成在全国各大、中城市设有350多个分支机构，并建立了销售服务网络，拥有一支庞大的销售服务队伍。

Service Network

With a strong team of sales promotion and after-sales-service, Liancheng established more than 350 nationwide branches in various large and middle.

服务项目

- 技术培训
- 安装调试
- 维护修理保养
- 设备评估
- 故障处理
- 设备升级改进

Service Items

- Technical training
- Equipment evaluation
- Installation and adjustment
- Trouble-shooting
- Maintenance and repairing
- The modification & improvement of equipment

服务承诺

- 合同签约后，在安装期间本公司将派人无偿到现场协助安装及调试；
- 如您按说明书正确使用上海连成牌水泵能确保您使用满意，万一发生异常情况，即请拨打服务热线，我们将为您提供优质的售后服务，给予您满意的答复；
- 产品保修期为一年，一年之内如产品出现质量问题，本公司将实行三包；一年以后出现产品质量问题，本公司提供无偿的技术服务，需方单位自购零配件；
- 产品售出后，本公司将终生与客户保持联系，听取使用意见，以便使产品质量更加完善；
- 本公司将定期与订购单位保持联系，定期回访，以确保订购单位使用的设备运行处于良好状态。

Service Promise

After signing the contract, technical persons will be dispatched to the instant site to help install and adjust equipment, which is free of charge.

In case the equipment is manipulated in accordance with instruction of tech manual, Shanghai Liancheng will guarantee the products. If something abnormal occurred, please contact us. Shanghai Liancheng will provide consider. Within the warrant period of 1 year, if products have quality problems, Liancheng will provide charge-free services.

After warrant period, if quality problems occur, will provide the charge-free technical support, the components and parts should be bought by customers.

After the products are purchased, Shanghai Liancheng will keep lifelong contact with the customers, listening comments from customers so as to improve quality in pump performance.

Shanghai Liancheng will keep regular contact with ordering companies so as to have pump running in proper order.

境内售后服务请与我公司当地售后联系或总部：021-59136786

For the domestic post-sale service, please contact the local post-sale service and the headquarter: 021-59136786

境外销售和售后服务请联系：+86 21 59136780

For the abroad sale and post-sale service, please contact: +86 21 59136780

驻外机构：_____

Agency : _____